

CIRCUITMEDIC

**First-aid kits for circuit boards,
time-tested and guaranteed.**

Multiple Product Instruction Manual

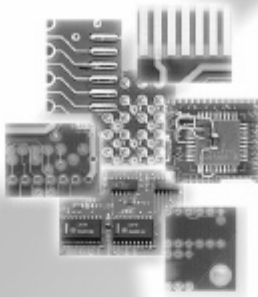

Manual No. 115-1803

CircuitMedic Product Instruction Manual

Circuit Board Repair and Rework

**This manual covers many products and procedures.
See the index for details.**

**For more information visit CircuitMedic
www.circuitmedic.com**

© Copyright 2006
CircuitMedic
135 Ward Hill Avenue
Haverhill, MA 01835 USA
Phone: 978-373-1600
E-mail: info@circuitmedic.com

Specifications for products are subject to change without notice. If there are critical specifications, they should be noted when products are ordered. Contact your local distributor for current price and delivery information.

All CircuitMedic products are of high quality and manufactured in conformance with the best commercial practices. CircuitMedic guarantees that all products will be free of defects at the time of shipment. We will replace without charge, any product found to be defective, provided the defect is reported to CircuitMedic with 90 days from the date of shipment. Visit our web site for return instructions. This guarantee shall not apply to any product that has been subject to misuse, misapplication, neglect, accident, improper installation or modification.

The information in this document is subject to change without notice. CircuitMedic disclaims all warranties with regard to information printed in this document. This disclaimer includes all implied warranties of merchantability and fitness for a particular purpose. In no event shall CircuitMedic be liable for any special, indirect or consequential damages or any damages whatsoever resulting from loss of use, data, or profits, arising out of, or in connection with, the use of any product or technique covered in this document.

<u>General Information</u>		<u>Page</u>
Introduction		1
IPC Compliance		1

<u>Product Information</u>	<u>Product No.</u>	<u>Page</u>
Professional Repair Kit	201-2100	2
Micro Pad Repair Kit	201-1100	5
Gold Contact Repair Kit	201-1120	7
Land Repair Kit	201-1110	9
Circuit Bonding System	115-3118	11
Circuit Frames		15
Bonding Tips		16
Circuit Track Kit	201-3130	17
Plated Hole Repair Kit	201-3140	18
Eyelet Press	110-5202	20
Eyelets		22
Base Board Repair Kit	201-3110	24
Epoxy Kit	115-1322	26
Color Agents		28
Gold Contact Plating Kit	201-6100	29
Micro-Drill System	110-4102	31

<u>Process Instructions</u>	<u>IPC Ref.*</u>	<u>Page</u>
Foreword	1.0	34
Basic Procedures	---	
Coating Removal, Grinding/Scraping	2.3.5	36
Coating and Solder Mask Repair	2.4.1	48
Base Material Repair	---	
Delamination/Blister Repair	3.1	40
Hole Repair, Epoxy Method	3.3.1	42
Hole Repair, Transplant Method	3.3.2	44
Base Board Repair, Epoxy Method	3.5.1	46
Base Board Repair, Edge Transplant Method	3.5.3	48
Conductor/Land/PTH Repair	---	
Lifted Conductor Repair	4.1.2	51
Conductor Repair, Foil Jumper	4.2.1	54
Circuit Cuts	4.3.1	57
Land Repair	4.5.2	59
Gold Contact Repair	4.6.2	62
Gold Contact Plating	4.6.3	65
Surface Mount Pad Repair	4.7.2	73
BGA Pad Repair	4.7.3	76
Plated Hole Repair	5.1	79

Introduction

This multipurpose manual includes set up information and operation procedures for many CircuitMedic products. Also included are detailed step by step instructions, for a wide range of circuit board repair and rework operations.

Before attempting circuit board repair or rework we recommend that you carefully read over all the information relative to the particular products you will be using and the procedures you be following.

This manual is divided into 2 main sections.

Section	Use
Product Information Pages 2 - 33	Refer to this section to learn how to set up and use the various materials and tools supplied with each product or kit.
Process Instructions Pages 34 - 81	Refer to this section to learn how to repair and rework circuit boards using the materials and tools supplied with each product or kit.

**For the latest information visit our company
web site at www.circuitmedic.com**

IPC Compliance

Most of the products referenced in this manual are designed to comply with procedures referenced in the popular IPC document number [IPC 7721 Modification and Repair of Printed Boards and Electronic Assemblies](#).

IPC - Association Connecting Electronics Industries is one of the world's leading electronics standards organizations and is located in Northbrook, IL. USA. For over 40 years, the IPC has helped to guide the electronic interconnection industry through dramatic changes. It has been and still is the only trade association that brings together all of the players in this industry: designers, board manufacturers, assembly companies, suppliers, and original equipment manufacturers. As members of IPC, proactive participants work together to meet the challenges and ensure the future of a very important industry. For more information visit the IPC web site at www.ipc.org.

Professional Repair Kit

201-2100 Professional Repair Kit, 120 VAC

201-2102 Professional Repair Kit, 230 VAC

Introduction

The Professional Repair Kit is the most complete and most versatile circuit board repair kit you'll find anywhere. It's the total package. The kit includes dry film, epoxy-backed circuit frames, the unique replacement circuits that require no messy liquid epoxy. There are eyelets and setting tools for plated through hole repair, Circuit Tracks to repair damaged circuits, epoxy and color agents for solder mask or base board repairs, and a comprehensive manual...all packaged in a convenient carrying case. If you need to repair damaged circuit boards, the all-in-one Professional Kit is just what you need.

Note: For small (under .040" wide) pads and contacts the Circuit Bonding System is recommended to more precisely control the bonding force. See page 11.

Features

- Complete - has everything you need to repair multiple types of board damage.
- Economical - easy to use, all kit components designed to save you time and money.
- Convenient packaging - contents neatly arranged in handy carrying case.
- Comprehensive Manual - a complete "how to" book on board repair and rework.
- Industry approved - our most popular kit for board work that meets IPC guidelines.
- Quality throughout - all components are prime quality, time-tested, to meet our high standards, and yours.

Specifications

Power - #115-3102 Bonding Iron:	120 VAC, 50/60 Hz
Power - #115-3103 Bonding Iron:	230 VAC, 50/60 Hz
Heat Output Approx.:	20 Watts, 500°F (260 °C)
Heat Up Time Approx.:	10 minutes
Circuit Frames:	See Page 15
Epoxy:	See Page 26
Circuit Tracks:	See Page 17
Eyelets:	See Page 24



Professional Repair Kit
Universal tool kit for circuit board damage repair.

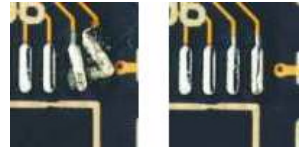

Includes adhesive backed pads for surface mount pad repair.



Includes gold plated replacement edge contacts for gold contact repair.

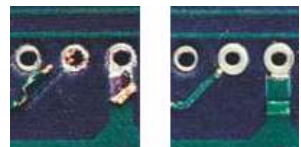

Includes replacement lands for land repair and eyelets for plated through hole repair.

<u>Process Instructions</u>	<u>IPC Ref.*</u>	<u>Page</u>
Coating and Solder Mask Repair	2.4.1	38
Delamination/Blister Repair	3.1	40
Hole Repair, Epoxy Method	3.3.1	42
Hole Repair, Transplant Method	3.3.1	44
Base Board Repair, Epoxy Method	3.5.1	46
Base Board Repair, Edge Transplant	3.5.3	48
Lifted Conductor Repair	4.1.2	51
Conductor Repair, Foil Jumper	4.2.1	54
Land Repair	4.5.2	59
Gold Contact Repair	4.6.2	62
Surface Mount Pad Repair	4.7.2	73
BGA Pad Repair	4.7.3	76
Plated Hole Repair	5.1	79

* Reference to IPC 7721 Repair and Modification of Printed Boards and Electronic Assemblies.

Setup

1. Plug in Bonding Iron and allow 10 minutes to warm up.

Caution

Bonding iron operates at high temperature. Observe necessary precautions to prevent injury.

2. When changing tips allow 1 minute for tip temperature to stabilize.

Parts List

<u>Part No.</u>	<u>Description</u>	<u>Qty</u>
115-6002	Ball Mill, Carbide, #2, .039" Diameter	1
115-6003	Ball Mill, Carbide, #3, .047" Diameter	1
115-6004	Ball Mill, Carbide, #4, .055" Diameter	1
115-6005	Ball Mill, Carbide, #5, .063" Diameter	1
115-6006	Ball Mill, Carbide, #6, .071" Diameter	1
115-6007	Ball Mill, Carbide, #7, .083" Diameter	1
115-6050	Ball Mill, Carbide, #1/2, .027" Diameter	1
115-3962	Base Board Transplant, FR4, .062" Thk.	2
115-3993	Base Board Transplant, FR4, .093" Thk.	2
115-2706	Bonding Film, 2.25" x 1.50"	1
115-3102	Bonding Iron, 120 VAC	1
115-2104	Bonding Tip, Tapered	1
115-2202	Bonding Tip, .060" Diameter	1
115-2205	Bonding Tip, .035" Diameter	1
115-2210	Bonding Tip, .100" Diameter	1
115-2304	Bonding Tip, .025" x .080"	1
115-2306	Bonding Tip, .040" x .060"	1
115-2318	Bonding Tip, .080" x .500"	1
CS025035AS	Circuit Frame, BGA Pads .025"/.035"	1

CC050060AG	Circuit Frame, Contacts .050"/.060"	1
CC070080AG	Circuit Frame, Contacts .070"/.080"	1
CP050060AS	Circuit Frame, PTH Pads .050"/.060"	1
CP070080AS	Circuit Frame, PTH Pads .070"/.080"	1
CP090100AS	Circuit Frame, PTH Pads .090"/.100"	1
CSVAR1AS	Circuit Frame, SMP Variety	1
CFV003T	Circuit Frame, Variety	1
115-5206	Circuit Track, .002" x .006"	1
115-5210	Circuit Track, .002" x .010"	1
115-5315	Circuit Track, .003" x .015"	1
115-5530	Circuit Track, .005" x .030"	1
115-9348	Color Agent, PMS 348	1
115-9358	Color Agent, PMS 358	1
115-3302	Epoxy	4
115-7306	Eyelet, Flat Flange .030" ID x .093" LUF	50
115-7336	Eyelet, Flat Flange .033" ID x .093" LUF	50
115-7366	Eyelet, Flat Flange .036" ID x .092" LUF	50
115-7456	Eyelet, Flat Flange .045" ID x .093" LUF	50
115-3132	File	1
235-2102	Foam Swab	4
355-2102	Knife	1
115-3138	Mill Handle	1
115-3314	Mixing Stick	4
115-3312	Plastic Cup	4
115-3360	Plastic Probe	4
115-3108	Practice Board	1
115-3362	Rod, FR4, .093" Diameter	1
115-3364	Rod, FR4, .125" Diameter	1
115-3366	Rod, FR4, .187" Diameter	1
355-4235	Saw Blade	1
115-3120	Setting Tool	2
115-3902	Syringe Assembly	3
115-3122	Tool Base	1
115-3134	Tool Handle	1
335-5183	Tweezer	1
115-1352	Tape Dots	10
950-4508	Tape, Kapton	1
115-3142	Tip Tool	1

Notes

Micro Pad Repair Kit

201-1100 Micro Pad Repair Kit, 120 VAC

201-1102 Micro Pad Repair Kit, 230 VAC

Introduction

This kit includes the tools and materials needed to reliably replace damaged surface mount and BGA pads. The unique Circuit Frames are made from rolled, annealed copper electroplated with solder and finished with dry film adhesive backing. You simply select the appropriate size pad, trim it from the Circuit Frame and bond it to the circuit board surface. Included with the kit are a bonding iron and tips to match the various sizes of the surface mount and BGA pads. A multifunctional epoxy is included for over coating the lap solder joint formed between the replacement pad and connecting circuitry.

Note: For small (under .040" wide) surface mounts and BGA pads the Circuit Bonding System is recommended to more precisely control the bonding force. See page 11.

Features and Benefits

- Industry approved - meets IPC guidelines
- Complete - everything required to replace damaged surface mount and BGA pads
- Convenient packaging in ESD safe carry case
- Variety - hundreds of replacement pads plus custom shapes available.

Specifications

Power - #115-3102 Bonding Iron:	120 VAC, 50/60 Hz
Power - #115-3103 Bonding Iron:	230 VAC, 50/60 Hz
Heat Output Approx.:	20 Watts, 500°F (260 °C)
Heat Up Time Approx.:	10 minutes
Circuit Frames:	See Page 15
Epoxy:	See Page 26

Process Instructions

<u>Process Instructions</u>	<u>IPC Ref.*</u>	<u>Page</u>
Surface Mount Pad Repair	4.7.2	73
BGA Pad Repair	4.7.3	76

* Reference to [*IPC 7721 Repair and Modification of Printed Boards and Electronic Assemblies.*](#)



Micro Pad Repair Kit
Kit for repair of damaged surface mount and BGA pads.

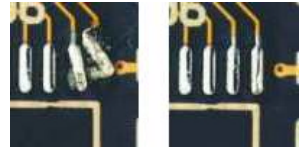

Includes adhesive backed pads for surface mount and BGA pad repair.

Setup

1. Plug in Bonding Iron and allow 10 minutes to warm up.

Caution

Bonding iron operates at high temperature. Observe necessary precautions to prevent injury.

2. When changing tips allow 1 minute for tip temperature to stabilize.

Parts List

Part No.	Description	Qty
115-3102	Bonding Iron, 120 VAC	1
115-2104	Bonding Tip, Tapered	1
115-2205	Bonding Tip, .035" Diameter	1
115-2306	Bonding Tip, .040" x .060"	1
115-2320	Bonding Tip, .095" x .095"	1
CS025035AS	Circuit Frame, BGA Pads .025"/.035"	1
CSVAR1AS	Circuit Frame, SMP Variety	2
115-3302	Epoxy	4
235-2102	Foam Swab	4
355-2102	Knife	1
115-3314	Mixing Stick	4
115-3312	Plastic Cup	4
115-3360	Plastic Probe	4
950-4508	Tape, Kapton	1
115-3142	Tip Tool	1
335-5183	Tweezer	1

Notes

Gold Contact Repair Kit

201-1120 Gold Contact Repair Kit, 120 VAC

201-1122 Gold Contact Repair Kit, 230 VAC

Introduction

Repairing gold edge contacts on circuit boards is delicate work, but this kit helps make the process easier and more reliable. Simply select the correct size and shape of gold plated contact from the Circuit Frames included in the kit and bond it in place. These unique replacement circuits have a dry film, adhesive backing that is activated and cured with heat and pressure. This IPC recommended repair method restores your boards to their original level of performance and reliability.

Note: For small (under .040" wide) pads and contacts the Circuit Bonding System is recommended to more precisely control the bonding force. See page 11.

Note: When gold edge contacts become contaminated with solder consider using the Gold Contact Plating Kit. See page 29.

Features and Benefits

- Industry approved - meets IPC guidelines
- Dry film epoxy backing on Circuit Frames eliminates messy epoxies
- Replacement contacts are supplied - nickel and gold plated
- Kit contains everything needed for gold edge contact repairs
- Circuit Frames supplied in variety of shapes and sizes or can be customized to meet your specific needs.

Specifications

Power - #115-3102 Bonding Iron:	120 VAC, 50/60 Hz
Power - #115-3103 Bonding Iron:	230 VAC, 50/60 Hz
Heat Output Approx.:	20 Watts, 500°F (260 °C)
Heat Up Time Approx.:	10 minutes
Circuit Frames:	See Page 17
Epoxy:	See Page 30

Process Instructions

Gold Contact Repair

IPC Ref.*

4.6.2

Page

62

* Reference to [IPC 7721 Repair and Modification of Printed Boards and Electronic Assemblies.](#)



Gold Contact Repair Kit
Kit for repair of damaged gold edge contacts.

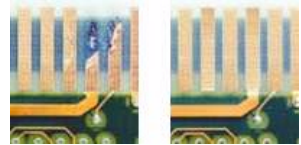

Includes gold plated adhesive backed pads for gold contact repair. See page 62.

Setup

1. Plug in Bonding Iron and allow 10 minutes to warm up.

Caution

Bonding iron operates at high temperature. Observe necessary precautions to prevent injury.

2. When changing tips allow 1 minute for tip temperature to stabilize.

Parts List

<u>Part No.</u>	<u>Description</u>	<u>Qty</u>
115-3102	Bonding Iron, 120 VAC	1
115-2104	Bonding Tip, Tapered	1
115-2314	Bonding Tip, .060" x .500"	1
115-2318	Bonding Tip, .080" x .500"	1
115-2322	Bonding Tip, .120" x .500"	1
CC050060AG	Circuit Frame, Contacts .050"/.060"	1
CC070080AG	Circuit Frame, Contacts .070"/.080"	2
115-3302	Epoxy	4
115-3132	File	1
235-2102	Foam Swab	4
355-2102	Knife	1
115-3314	Mixing Stick	4
115-3312	Plastic Cup	4
115-3360	Plastic Probe	4
950-4508	Tape, Kapton	1
115-3142	Tip Tool	1
335-5183	Tweezer	1

Notes

Land Repair Kit

201-1110 Land Repair Kit, 120 VAC

201-1112 Land Repair Kit, 230 VAC

Introduction

Problems with lifted or damaged lands on circuit boards? You'll find the solution in this kit that is specifically designed to make the repair process as simple and effective as possible. The handy ESD safe carrying kit contains replacement lands in a wide variety of sizes, epoxy, bonding tips, tape, and many other items to help you do a professional job.

Note: For small (under .040" wide) lands and pads the Circuit Bonding System is recommended to more precisely control the bonding force. See page 11.

Features and Benefits

- Complete - kit includes everything you need for land repair or replacement
- Industry approved - conforms to IPC guidelines
- Step-by-step instructions included
- Dry film backing on replacement lands eliminates need for messy liquid epoxies
- Packaged in a handy ESD safe carrying case

Specifications

Power - #115-3102 Bonding Iron:	120 VAC, 50/60 Hz
Power - #115-3103 Bonding Iron:	230 VAC, 50/60 Hz
Heat Output Approx.:	20 Watts, 500°F (260 °C)
Heat Up Time Approx.:	10 minutes
Circuit Frames:	See page 15
Epoxy:	See page 28

<u>Process Instructions</u>	<u>IPC Ref.*</u>	<u>Page</u>
Land Repair	4.5.2	59

* Reference to IPC 7721 Repair and Modification of Printed Boards and Electronic Assemblies.

Setup

1. Plug in Bonding Iron and allow 10 minutes to warm up.

Caution

Bonding iron operates at high temperature. Observe necessary precautions to prevent injury.

2. When changing tips allow 1 minute for tip temperature to stabilize.



Land Repair Kit
Kit for repair
of damaged lands.

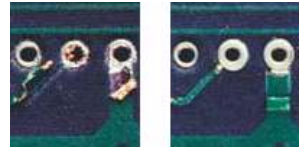

*Includes adhesive backed
lands for land repair.*

Parts List

<u>Part No.</u>	<u>Description</u>	<u>Qty</u>
115-3102	Bonding Iron, 120 VAC	1
115-2104	Bonding Tip, Tapered	1
115-2202	Bonding Tip, .060" Diameter	1
115-2210	Bonding Tip, .100" Diameter	1
115-2314	Bonding Tip, .060" x .500"	1
CP050060AS	Circuit Frame, PTH Pads .050"/.060"	1
CP070080AS	Circuit Frame, PTH Pads .070"/.080"	1
CP090100AS	Circuit Frame, PTH Pads .090"/.100"	1
115-3302	Epoxy	4
235-2102	Foam Swab	4
355-2102	Knife	1
115-3314	Mixing Stick	4
115-3312	Plastic Cup	4
115-3360	Plastic Probe	4
950-4508	Tape, Kapton	1
115-3142	Tip Tool	1
335-5183	Tweezer	1

Notes

Circuit Bonding System

115-3118

Circuit Bonding System, w/Temperature Controller, 120 VAC

115-3119

Circuit Bonding System, w/Fixed Temperature, 120 VAC

115-3218

Circuit Bonding System, w/Temperature Controller, 230 VAC

115-3219

Circuit Bonding System, w/Fixed Temperature, 230 VAC



Circuit Bonding System

Bonding system to accurately control circuit bonding.

Introduction

The Circuit Bonding System includes a heater attached to a calibrated slide to provide a precise load when bonding replacement circuits to circuit boards. This system has a 12" throat depth and 6" vertical travel allowing rework on circuit boards up to 24" wide. Vibrations and fatigue caused by holding a Bonding Iron free hand are eliminated, control is enhanced, and your hands are free for other tasks.

Features

- Precision design - permits bonding of minute patterns.
- Heavy duty construction - ensures platform stability.
- Built-in calibration slide maintains regulated bonding force.
- Temperature controller maintains uniform bonding temperature for better results.

Specifications

Frame Construction:	11 gauge steel
Throat Depth:	12 in. (30.0 cm)
Throat Height:	7" (17 cm)
Vertical Travel:	7" (17 cm)
Weight:	10 lb. (4.5 kg.)
Power Input:	85 to 265 VDC/VAC 50 to 400 Hz 5 VA max.
Temperature Controller	
Range:	Ambient to 990°F (871°C)
Resolution:	1°F (1°C)
Cycle Time:	2 to 80 sec.
Power Consumption	5 VA max.
Heat Output:	20 Watts
Heat Up Time:	10 minutes

These systems may be used with the following kits:

Product	Product No.	Page
Professional Kit	201-2100	2
Micro Pad Repair Kit	201-1100	5
Gold Contact Repair Kit	201-1120	7
Land Repair Kit	201-1110	9

Process Instructions	IPC Ref.*	Page
Land Repair	4.5.2	59
Gold Contact Repair	4.6.2	62
Surface Mount Pad Repair	4.7.2	73
BGA Pad Repair	4.7.3	76

Setup

1. Clamp the Arm to a work bench using the Table Clamp. The Arm can also be bolted to a work bench using the 4 holes in the base.
2. Lower the slide and use a mechanical square to check that the face is perpendicular to the work surface. (See Figure Below). To adjust the slide, loosen the (2) lower screws on each side of the Arm and adjust as needed.

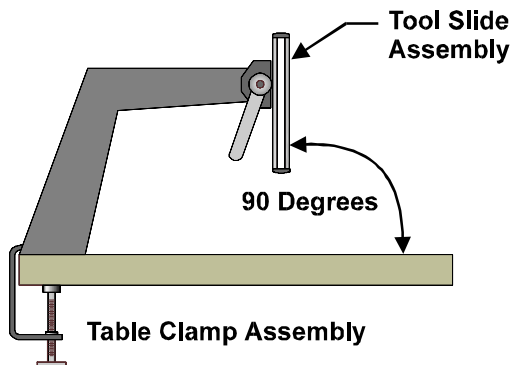

3. The handles may be repositioned by pulling out and rotating.

Temperature Controller

If the system includes a Temperature Controller it will come factory set at 500 °F (260 °C). To adjust the temperature follow this procedure.

1. Plug the system in to the power source and turn on the power.
2. Depress the Temperature Indication Switch. The "SP" (set point) will light up.



3. Adjust the up or down Temperature Switch to set the desired operating temperature. Normally set to 500 °F (260 °C).



4. Depress the Temperature Indication Switch twice to indicate the true temperature.

Operation

1. Prepare the circuit board depending on the circuit pattern to be bonded. See procedures for surface mount pad, BGA pad, land, conductor, or edge contact repair in this manual.
2. Select a Bonding Tip to match the shape of the new circuit. (See page 20 for a list of sizes)

Note

The Bonding Tip should be as small as possible but cover the entire surface of the new circuit.

3. Insert the Bonding Tip into the heater of the Circuit Bonding System. Turn the system on and provide adequate time for the temperature to stabilize. Normal operating temperature is set to 500 °F (260 °C).
4. Place the circuit board in position and accurately align the new circuit below the Bonding Tip. Test the alignment by lowering the Bonding Tip until it nearly touches the new circuit.

Note

Check to be sure the bottom of the Bonding Tip is parallel to surface of the circuit board.

5. Determine the Bonding Setting. See the CircuitMedic web site for details at www.circuitmedic.com/circuitframes

6. Position the circuit board so that it is flat and stable. Lower the handle until the hot the hot Bonding Tip contacts the Kapton tape holding the new circuit in position. (Refer to appropriate procedure for information about new circuit preparation.) Turn the handles to lower the Bonding Tip to the proper setting indicated by the calibration marks. Leave Bonding Tip in position for only 5 seconds to tack the new circuit in place, then immediately raise the Bonding Tip using the handle.

7. Carefully peel off the Kapton tape that was used to temporarily hold the new circuit in place. Turn the handle to lower the hot the hot Bonding Tip to the proper setting indicated by the calibration marks. Heat will be applied directly to the new circuit. Leave the Bonding Tip in position for an additional 30 seconds to fully bond the new circuit, then immediately raise the Bonding Tip using the handle.

8. Complete the repair procedure per the additional instructions in this manual.

System Calibration

Load settings on the Calibration Slide should be periodically checked. Loads can be verified using a force gauge or other measuring device. Load setting tolerance is ± 20 percent of the set point mark.

Maintenance

No particular maintenance is needed.

Notes

Circuit Frames

Introduction

Imagine replacing damaged circuits without the mess of liquid epoxy, with a bond strength equal to the original, on bare or loaded circuit boards -- all in about 30 seconds. Our replacement Circuit Frames with dry-film epoxy backing make this delicate, precise procedure quick and neat. Trim out the circuit you need and bond it to the circuit board surface with a bonding iron or bonding press. Choose from hundreds of different shapes or let us custom design and fabricate that special shape for you.

Material Specifications

Frame Size:	2.25" x 1.50" (57 x 38 mm)
Base Material:	Rolled annealed copper foil .0014" (.036 mm) thick
Adhesive Backing:	Phenolic Butral film adhesive .0018" (.046 mm) thk.
Bonding Temperature:	475°F ± 25°F (246°C ± 14°C)
Bonding Time:	30 seconds
Bonding Load:	See Calibration Settings
Peel Strength:	Minimum 8 lbs/inch (1.43 kg/cm) After cure to FR-4 material
Shelf Life:	6 months. Circuit Frames are stamped with an expiration date.

Plating Specifications

S - Tin:	.0005" (.0127 mm) Bright Tin min.
G - Nickel/Gold:	.000050" (.00127 mm) gold over .000100" (.00254 mm) nickel min.
T - Tin/Lead:	.001" (.0254 mm) 60/40 tin/lead min. U
- Unplated:	No plating

Bonding Load

To obtain the maximum bond of the Circuit Frame to the circuit board surface, the proper combination of heat, time, and bonding load are required. The Bonding Load is based on the approximate surface area of the circuit being bonded.

Visit the CircuitMedic web site for the full selection of available Circuit Frames

www.circuitmedic.com/circuitframes

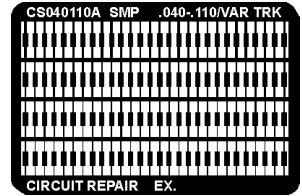

Surface Mount Pads

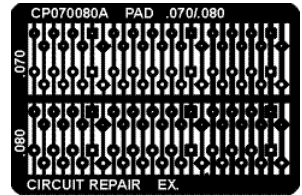

Lands and Conductors

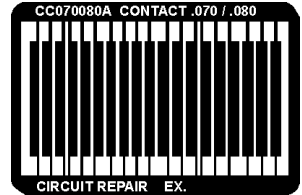

Gold Edge Contacts

Bonding Tips

Bonding Tips are precisely machined, high quality aluminum tips used to bond replacement circuits to circuit board surfaces.

Bonding Tip Material Specifications

Material: 6061 Aluminum
Shank Size: .250" (6.35 mm) Diameter

<u>Part Number</u>	<u>Description</u>	<u>Type</u>
115-2302	.012" x .060" (0.30 x 1.52 mm)	A
115-2304	.025" x .080" (0.64 x 2.03 mm)	A
115-2308	.045" x .110" (2.24 x 2.79 mm)	A
115-2310	.050" x .050" (1.27 x 1.27 mm)	A
115-2312	.060" x .080" (1.52 x 2.03 mm)	A
115-2316	.080" x .120" (2.03 x 3.05 mm)	A
115-2320	.095" x .095" (2.41 x 2.41 mm)	A
115-2104	Tapered	B
115-2202	.060" (1.52 mm) Diameter	B
115-2290	.090" (2.30 mm) Diameter	B
115-2206	.120" (3.05 mm) Diameter	B
115-2314	.060" x .500" (1.52 x 12.70 mm)	C
115-2318	.080" x .500" (2.03 x 12.70 mm)	C
115-2322	.120" x .500" (3.05 x 12.70 mm)	C

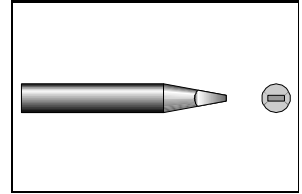

Type A
Small Rectangular
Pad Style

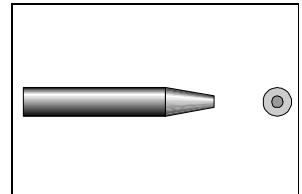

Type B
Round Pad Style

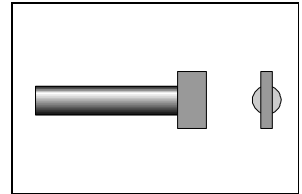

Type C
Large Rectangular
Pad Style

Circuit Track Kit

201-3130 Circuit Track Kit

Introduction

Circuit Tracks are rectangular shaped conductors made of 99.9% pure CDA 11000 copper. These rectangular ribbons closely conform to the original conductor dimensions. Circuit Tracks are bonded in place using prepackaged epoxy included in the kit. This kit is a great time and labor-saver and an easy solution to repairing missing or damaged circuits.



Circuit Track Kit

Universal tool kit for circuit board damage repair.

Features and Benefits

- Meets IPC recommended guidelines
- Versatile - conform to any pattern
- Convenient packaging - easy to use

Specifications

Material: 99.90% pure CDA 11000 Copper
 Package Size: 36" (90 cm) Long
 Epoxy: See page 26

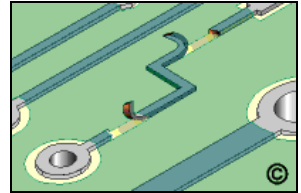

Process Instructions

Conductor Repair, Foil Jumper

IPC Ref.*

4.2.1

Page

54

Includes Circuit Tracks for conductor repair.

* Reference to *IPC 7721 Repair and Modification of Printed Boards and Electronic Assemblies.*

Setup

No special setup is required. Refer to Application Instructions.

Parts List

<u>Part No.</u>	<u>Description</u>	<u>Qty</u>
115-5205	Circuit Track, .002" x .005"	1
115-5206	Circuit Track, .002" x .006"	1
115-5208	Circuit Track, .002" x .008"	1
115-5210	Circuit Track, .002" x .010"	1
115-5312	Circuit Track, .003" x .012"	1
115-5315	Circuit Track, .003" x .015"	1
115-5520	Circuit Track, .005" x .020"	1
115-5530	Circuit Track, .005" x .030"	1
115-3302	Epoxy	4
115-3310	Eraser	1
355-2102	Knife	1
115-3314	Mixing Stick	4
115-3312	Plastic Cup	4
335-5183	Tweezer	1

Plated Hole Repair Kit

201-3140 Plated Hole Repair Kit

Introduction

Here are all the tools and materials you'll need to repair damaged plated through holes in circuit boards. The kit includes a variety of eyelet sizes, carbide ball mills for drilling, and setting tools to form the eyelets conforming to IPC guidelines. Eyelets are made of pure copper electroplated with solder. Eyelet tooling is hardened steel.

Features and Benefits

- Eyelets meet IPC Guidelines
- Versatile - has everything you need to repair plated holes in a wide variety of sizes

Specifications

Eyelets: See page 22

Process Instructions

Plated Hole Repair

IPC Ref.*

5.1

Page

79

* Reference to *IPC 7721 Repair and Modification of Printed Boards and Electronic Assemblies*.

Setup

1. Place one Setting Tool into the Tool Base. The cone shaped end should be inserted into the Tool Base.
2. Place the other Setting Tool into the Tool Handle with the cone shaped end out.
3. If needed, drill out the hole removing all the plating. The drilled hole should be .025 - .125 mm (.001" - .005") larger than the eyelet OD.
4. Insert the Eyelet into the circuit board and flare the eyelet end into a funnel shape. Apply light and even pressure. (See Figure 1).
5. Flip the Setting Tool around in the Tool Handle and flat set the Eyelet. Apply firm pressure to flat set the Eyelet. (See Figure 2).



Plated Hole Repair Kit
Kit for repair of damaged plated through holes.

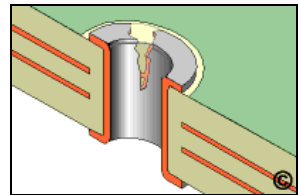

Includes eyelets and setting tools for plated through hole repair.

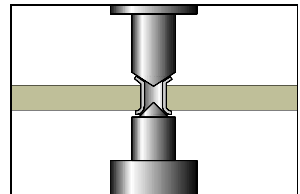

Figure 1: Flare the eyelet into a funnel shape

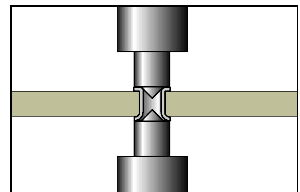

Figure 2: Flat set the Eyelet with the setting tool.

Notes

Parts List

<u>Part No.</u>	<u>Description</u>	<u>Qty</u>
115-6002	Ball Mill, Carbide, #2, .039" Diameter	1
115-6003	Ball Mill, Carbide, #3, .047" Diameter	1
115-6004	Ball Mill, Carbide, #4, .055" Diameter	1
115-6005	Ball Mill, Carbide, #5, .063" Diameter	1
115-6006	Ball Mill, Carbide, #6, .071" Diameter	1
115-6007	Ball Mill, Carbide, #7, .083" Diameter	1
115-7206	Eyelet, Flat Flange .020" ID x .094" LUF	50
115-7306	Eyelet, Flat Flange .030" ID x .093" LUF	50
115-7336	Eyelet, Flat Flange .033" ID x .093" LUF	50
115-7366	Eyelet, Flat Flange .036" ID x .092" LUF	50
115-7456	Eyelet, Flat Flange .045" ID x .093" LUF	50
115-7576	Eyelet, Flat Flange .057" ID x .095" LUF	50
115-8646	Eyelet, Funnel .064" ID x .091" LUF	50
115-8736	Eyelet, Funnel .073" ID x .093" LUF	50
115-3138	Mill Handle	1
115-3120	Setting Tool	2
115-3122	Tool Base	1
115-3134	Tool Handle	1

Eyelet Press

110-5202 Eyelet Press

Introduction

This rugged, heavy duty press precisely forms eyelets in circuit boards for repair or assembly. Has 6.50" throat depth to accommodate 13" wide circuit boards.

Features and Benefits

- Heavy duty construction for stable eyelet forming per IPC guidelines.
- Wide variety of tooling available - can form most commercially available eyelets.



Eyelet Press

Used to properly form eyelets for plated through hole repair.

Specifications

Throat Depth:	6.50" (16.50 cm)
Minimum Throat Opening:	1.00" (2.54 cm)
Tooling Shank Size:	.375" (9.52 mm) Diameter
Weight:	28 lbs. (13 kg.)

Process Instructions

Plated Hole Repair

IPC Ref.*

5.1

Page

79

* Reference to *IPC 7721 Repair and Modification of Printed Boards and Electronic Assemblies.*

Eyelet Press Setup

1. Be sure the Form Tool and Anvil Tool are perfectly aligned. The tips should touch when the press is lowered. If the tips are not aligned, loosen the four mounting bolts and adjust as needed.
2. The Setting Tool, with the stationary tip, should be fastened inside the upper Tool Support.
3. The Anvil Tool, with the spring tip, should be fastened in the lower Tool Holder.

Operation

1. If needed, drill out the plated hole removing all the plating. The drilled hole should be .025 - .125 mm (.001" - .005") larger than the eyelet outside diameter.
2. Insert the Eyelet into the circuit board. Carefully turn the circuit board over and place the Eyelet flange onto the Anvil Tool.

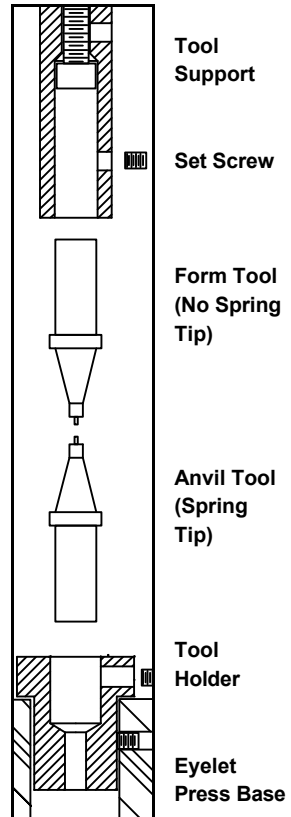

Eyelet Press tooling setup.

-
3. Lower the Form Tool and apply firm, even pressure to set the Eyelet in place.

Notes

Eyelets

Introduction

Eyelets are used repair damaged plated through holes on circuit boards. The barrel of the eyelet replaces the wall of the hole. The eyelet flanges replace the lands on the circuit board surface.

Note

This manual describes the use of eyelets to repair damaged plated through holes that do not have inner layer connections. For information about repairing plated holes with inner layer connections visit our web site at www.circuitmedic.com.

Specifications

Material: Pure Copper
Finish: Electroplated with pure Tin.

Eyelet Selection Criteria

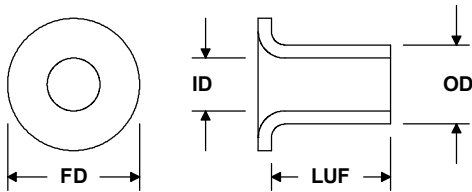

ID - Inside Diameter

The eyelet inside diameter should be a .075 - .500 mm (.003"-.020") greater than the component lead diameter.

LUF - Length Under Flange

The length of the eyelet barrel under the flange should be .630 - .890 mm (.025" - 035") greater than the thickness of the circuit board. This added length allows for proper protrusion when setting the eyelet.

FD - Flange Diameter

The eyelet flange diameter should be small enough to prevent interference with adjacent pads or circuits.

OD - Outside Diameter

The clearance hole should allow the eyelet to be inserted without force but should not exceed .125 mm (.005") greater than the eyelet outside diameter.

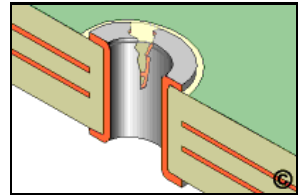

Eyelets are used to repair damaged plated through holes on circuit boards.

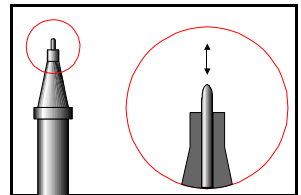

Anvil Setting Tools

Have a spring loaded pin that retracts when setting eyelets.

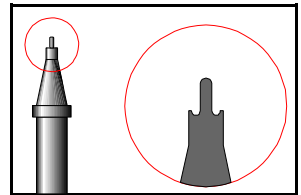

Form Setting Tools

Have a shaped area to form the eyelet flange.

**Visit the CircuitMedic web site
for the full selection of eyelets.**

www.circuitmedic.com/eyelets

Notes

Base Board Repair Kit

201-3110 Base Board Repair Kit

Introduction

Most types of damage to base board material can be repaired with this versatile repair kit. There are sections of FR4 to replace damaged board corners, edges and holes. The edge sections have a specially machined tongue along one edge to fit within a groove cut into the board edge. The kit includes epoxies, color agents, and dispensing cartridges.

Features and Benefits

- Versatile, complete - includes everything you need for base board repair
- Meets IPC guidelines
- High strength, high temperature epoxy withstands demanding physical environments
- Color agents permit matching of board colors
- FR4 laminate for compatible base board transplant applications.

Specifications

Epoxy: See page 26

Process Instructions	IPC Ref.*	Page
Coating and Mask Repair	2.4.1	38
Delamination/Blister Repair	3.1	40
Hole Repair, Epoxy Method	3.3.1/3.3.2	42
Base Board Repair, Surface Method	3.5.1	44
Base Board Repair, Edge Transplant	3.5.3	48

* Reference to *IPC 7721 Repair and Modification of Printed Boards and Electronic Assemblies.*

Setup

No special setup is required. Refer to Application Instructions.



Base Board Repair Kit
Used to repair defects in base board material and coatings.

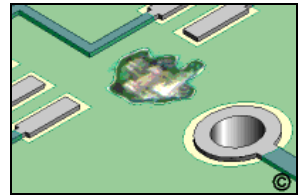

Includes high strength Epoxy and color agents for base board and coating repair.

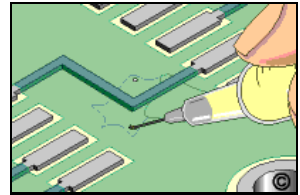

Includes Syringe Assemblies for delamination repair.

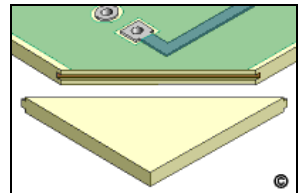

Includes transplant pieces of laminate for corner and edge repair.

Parts List

<u>Part No.</u>	<u>Description</u>	<u>Qty</u>
115-3962	Base Board Transplant, FR4, .062" Thk.	2
115-3993	Base Board Transplant, FR4, .093" Thk.	2
115-9348	Color Agent, PMS 348	1
115-9358	Color Agent, PMS 358	1
115-9376	Color Agent, PMS 376	1
115-3302	Epoxy	10
235-2102	Foam Swab	10
115-3314	Mixing Stick	10
115-3312	Plastic Cup	10
115-3360	Plastic Probe	10
115-3362	Rod, FR4, .093" Diameter	1
115-3364	Rod, FR4, .125" Diameter	1
115-3366	Rod, FR4, .187" Diameter	1
355-4235	Saw Blade	1
115-3902	Syringe Assembly	3
115-3134	Tool Handle	1

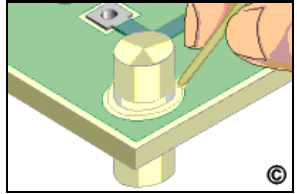

Includes laminate dowels for non plated hole repair.

Notes

Epoxy Kit

115-1322 Epoxy Kit

Introduction

This kit contains 10 packages of clear, low viscosity, superior strength epoxy, precisely measured out into two-compartment plastic packages so it's easy to use and there's no measuring. Once cured, this epoxy makes an effective electrical insulator with good high temperature mechanical and impact resistance properties. The epoxy can be used to fill in holes, gaps, burns or to inject into delaminated locations. The kit also contains mixing sticks, mixing cups and foam swabs.

Features

- Clear - can be tinted with coloring agents.
- High strength/high temperature - withstands demanding physical environments.
- Two-compartment packaging - eliminates mixing errors.

Epoxy Specifications - No. 115-3302

Packaging:	2 gram prepackaged containers
Color:	Clear, transparent
Pot life:	30 minutes
Cure cycle:	24 hours at room temperature or 1 hour @ 165°F (74°C)
Viscosity (after mixing):	1900 cps @ 77°F (25°C)
Operating temperature range:	-76°F to 284°F (-60°C to 140°C)
Hardness:	88 Shore D
Dielectric strength:	410 volts/mil

Process Instructions

	IPC Ref.*	Page
Coating and Solder Mask Repair	2.4.1	38
Base Board Repair, Epoxy Method	3.5.1	46

* Reference to *IPC 7721 Repair and Modification of Printed Boards and Electronic Assemblies*.

Mixing Instructions

1. The area where the Epoxy is to be applied should be prepared prior to mixing the Epoxy. This preparation may include preheating the affected area to improve absorption of the applied Epoxy. The entire circuit board may also be heated in an oven or with a heat lamp. Refer to the specific Application Instructions for more information.



Epoxy Kit

Used to repair minor defects in base board and coatings.

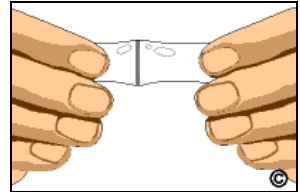

Figure 1: Remove divider clip and mix resin and hardener inside package.

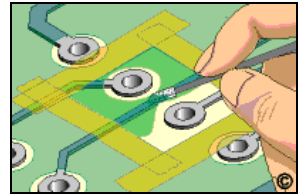

Figure 2: Epoxy can be used to replace damaged coatings and solder mask.

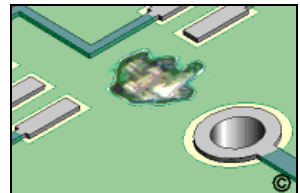

Figure 3: Epoxy can be used to repair damaged base board.

2. Remove the clip separating the resin and hardener. Mix by squeezing both halves together. Mix for at least one minute to ensure a complete mix of the resin and activator. (See Figure 1).
3. Cut open one end of the Epoxy package and squeeze the contents into a plastic cup. Mix again with a mixing stick to ensure a thorough mixture of the resin and hardener.

Note:

For bubble free Epoxy remove the clip separating the resin and hardener. Cut open one end of the Epoxy package and squeeze the entire contents into a plastic cup. Slowly stir the mixture with a mixing stick. Be sure to stir the mixture for at least 2 minutes to ensure that all the resin and hardener have completely mixed

4. If desired, add a drop of color agent to the mixed Epoxy. Stir slowly to prevent bubbles.
5. Apply or use as needed. Refer to the specific Application Instructions for more information.
6. Cure the Epoxy for 24 hours at room temperature or 1 hour @ 165°F (74°C)

Notes

Parts List

<u>Part No.</u>	<u>Description</u>	<u>Qty</u>
115-3302	Epoxy	10
235-2102	Foam Swab	10
115-3314	Mixing Stick	10
115-3312	Plastic Cup	10
115-3360	Plastic Probe	10

Color Agents

Matching epoxy to the color of the circuit board being repaired is a simple process when you use a color agent.

Color Agent Specifications

Packaging: 1 oz. packages

Note

The final color of Epoxy mixed with a Color Agent and applied to the surface of a circuit board may vary depending on the background the Epoxy is applied to and the amount of color agent used.

**Visit the CircuitMedic web site
for the full selection of Color Agents.**

www.circuitmedic.com

Gold Contact Plating Kit

201-6100 Gold Contact Plating System

Introduction

Here's the perfect kit for replating solder-contaminated or scratched gold edge contacts. The kit includes a DC power supply and all the tools and materials needed for gold edge contact plating. Plating probes use pre-wrapped, screw-on plating anodes to end the common problems associated with loosely wrapped cotton anodes. Plating solutions are available separately.

Features and Benefits

- Exclusive design - specifically for gold contact plating.
- Plating probes use pre-wrapped plating anodes.
- Industry approved - conforms to IPC guidelines.
- Variable power supply provides accurate voltage settings.

Power Supply Specifications

Power Input: 120 VAC

Process Instructions

Gold Contact Repair, Plating Method

IPC Ref.*

4.6.3

Page

65

Ideal system for replating solder contaminated gold contacts.

* Reference to [*IPC 7721 Repair and Modification of Printed Boards and Electronic Assemblies*](#).

Setup

1. Refer to: Gold Contact Plating on page 65.

Note

In order to prolong anode life and prevent contamination of probe ends, it is important to properly rinse probes after each use.

Caution

Do not rinse hazardous chemicals down the drain. Follow local and federal regulations regarding waste disposal.



Gold Contact Plating Kit
Used to replating and repair gold edge contacts.

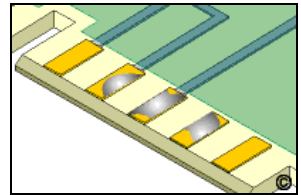

Ideal system for replating solder contaminated gold contacts.

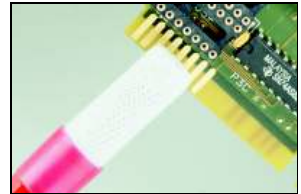

Includes standard plating anodes with prewrapped covers.

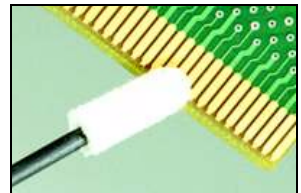

Includes small anodes for miniature contacts.

Parts List

Part No.	Description	Qty
115-3702	Abrasive Pad, White	10
510-2408	Alligator Clip	1
245-1102	Conductive Pen	1
250-1201	Conformal Coating Remover Pen	1
115-3106	Eraser Stick	1
235-2192	Foam Swab	10
355-2102	Knife	1
115-3312	Plastic Cup	10
115-3722	Plating Anode, Small	3
115-3721	Plating Anode, Standard	3
115-3742	Plating Cable, Black	1
115-3743	Plating Cable, Red	3
115-3752	Plating Probe, Black	1
115-3753	Plating Probe, Red	3
115-1714	Power Supply	1
290-3050	Tape, Polyester, 72 yds.	1
290-7150	Tape, Peel Testing, 60 yds.	1
115-3778	Wire, Buss, 30 AWG	1

Notes

Micro-Drill System

110-4102 Micro-Drill System, 120 VAC

110-4103 Micro-Drill System, 230 VAC

Introduction

The Micro-Drill is a workhorse in a kit. This versatile powerhouse is ideal for milling, drilling, grinding, cutting and sanding circuit boards. It removes coating, cuts circuits, cuts leads, drills holes, cuts slots, shapes FR4 and performs many other procedures using various interchangeable bits. Unlike most hand-held tools, the Micro-Drill has a tiny, high speed DC motor in the hand piece, eliminating bothersome drive cables and giving the technician better control. A separate power supply keeps the hand piece lightweight and reduces fatigue. Power is supplied by a panel switch or foot switch for ease of use.

Features and Benefits

- Dental quality construction for delicate board work .
- Flexible telephone-style cord eliminates bothersome drive cables.
- Quick change chuck for easy bit replacement.
- Versatile forward, reverse, and variable speeds.
- Small, lightweight, ergonomically designed hand piece reduces fatigue.
- Complete - includes ball mills, abrasive bits, and cutting discs.

Specifications

Power Input:	110/230 VAC, 50/60 Hz
Power Output:	0 - 30 VDC, 1 Amp
Tool Speed:	0 - 35000 RPM fully variable
Tool Shank:	.093" (2.36 mm) diameter
Fuse:	1 Amp or 1/2 Amp

Assembly

1. Plug the hand piece into the outlet in the front of the power supply.
2. Set the Forward/Reverse switch to Forward.
3. Plug the foot switch into the outlet in the back of the power supply.

Operation

1. Insert the proper Ball Mill or bit into the hand piece. To insert or change the bit, rotate the center section of the hand piece towards the R - Release and insert the correct bit. Lock the



Micro-Drill System
Dental quality drill for drilling, grinding, and cutting.

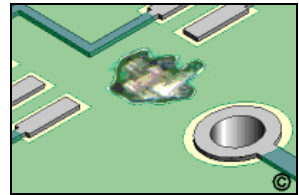

Ideal for grinding away burns and other surface defects.

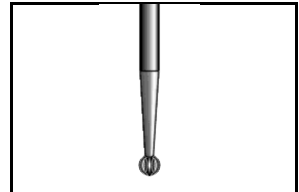

Includes carbide ball mills for accurate circuit cutting.

bit into the collet by rotating the center section of the hand piece toward the S - Secure.

2. Set the forward/reverse switch to the forward position.
3. Set the foot/hand switch to the foot operation setting.
4. Set the Power switch to the ON position. Red light indicates power.
5. Select the rotation speed desired by rotating the Speed Control knob.

Caution

Do not lubricate the motor.

Do not operate the system without a bit in the hand piece.

Do not attempt to open the collet while the hand piece is running.

Do not switch forward/reverse direction until the motor has stopped

Parts List

<u>Part No.</u>	<u>Description</u>	<u>Qty</u>
110-4602	Abrading Tip, Rubber	4
110-6064	Abrading Tip, Stone	1
110-4303	Accessory Stand	1
115-6001	Ball Mill, Carbide, #1, .031" Diameter	1
115-6002	Ball Mill, Carbide, #2, .039" Diameter	1
115-6003	Ball Mill, Carbide, #3, .047" Diameter	1
115-6004	Ball Mill, Carbide, #4, .055" Diameter	1
115-6005	Ball Mill, Carbide, #5, .063" Diameter	1
115-6006	Ball Mill, Carbide, #6, .071" Diameter	1
115-6007	Ball Mill, Carbide, #7, .083" Diameter	1
115-6025	Ball Mill, Carbide, #1/4, .019" Diameter	1
115-6050	Ball Mill, Carbide, #1/2, .027" Diameter	1
110-4622	Cutoff Disk	4
110-4502	Mandrel, Screw	1
110-4504	Mandrel, Threaded	1
950-1320	Micro-Drill Unit	1

Notes



Foreword

Today's complex circuit boards are a challenge to rework and repair. But despite the complexity of the work at hand they can be reworked and repaired reliably. To expect a reliable outcome, each repair project must follow proven and well established procedures. This combined guidebook and instruction manual is designed to help you repair and rework circuit boards that might otherwise be consigned to scrap.

CircuitMedic products have been used to repair and rework circuit boards for major companies around the world including IBM, Hewlett Packard, Siemens, Compaq Computer, AT&T, Allied Signal Aerospace, Lucent, Solectron, Celestica, Jabil and hundreds of other commercial and military manufacturers. The knowledge and skills needed for reliable rework and repair are indeed demanding. We suggest you visit our company web site at www.circuitmedic.com for expanded details on the procedures and tools for circuit board rework and repair. The procedures in this manual comply with standards set by IPC - Association Connecting Electronics Industries and includes:

J-STD-001	Requirements for Soldered Electrical and Electronic Assemblies
IPC-A-600	Acceptability of Printed Boards
IPC-A-610	Acceptability of Electronic Assemblies
IPC-7711	Rework of Electronic Assemblies
IPC-7721	Modification, Repair and Modification of Printed Boards and Assemblies.

Conformance Level

Each procedure in this manual includes a Conformance Level indicating how closely the repaired or reworked circuit board will be to the original specifications. Conformance Levels should be used as a guide only.

High - Most closely duplicates the physical characteristics of the original and most probably complies with all the functional, environmental and serviceability factors

Medium - Some variance with the physical character of the original and most likely varies with some of the functional, environmental and serviceability factors.

Low - Significant variance with the physical character of the original and may vary with many of the electrical, functional, environmental and serviceability factors.

Skill Level

Repair personnel should not be part-timers and repair circuit boards only one day a week or on a rotational basis with other duties. For challenging procedures to be done reliably, they must be done repeatedly. Personnel are key to the success of the whole repair operation. Three Skill Levels are referred to in this manual. The Skill Level should be used as a guide only.

Intermediate - Technician with skills in basic soldering and component rework but inexperienced in general repair/rework procedures.

Advanced - Technician with soldering and component rework skills and exposure to most repair/rework procedures but lacking extensive experience.

Expert - Technician with advanced soldering and component rework skills and extensive experience in most repair/rework procedures.

Cleaning

Surface contaminants can significantly effect soldering, bonding, coating, and electrical characteristics. Exercise care whenever cleaning circuit boards.

Summary

Repair is, and may always be, a highly labor intensive operation relying more on individual operator skills than automation. Contact CircuitMedic whenever assistance is needed.

**For more information visit
www.circuitmedic.com**

Coating Removal, Grinding/Scraping

Outline

This procedure describes the removal of coatings using either a scraping technique or grinding technique.

IPC Reference*

2.3.5 Coating Removal, Grinding/Scraping Method

Kits/Systems

Part No.	Description
110-4102	Micro-Drill System (See page 31)

Tools/Materials

Part No.	Description
-----	Ball Mills, Various Sizes
-----	Bristle Brushes
-----	Bullet Abrasive
-----	Cleaner
355-2102	Knife
110-4102	Micro-Drill System (See page 31)
-----	Wipes

Optional Items

-----	Microscope
115-1414	Pick
115-1416	Scraper

Procedure - Scraping Method

1. Clean the area.
2. Using a Knife or Scraper carefully scrape from side to side until the desired material is removed. (See Figure 1).
3. Remove all loose material and clean the area.

Procedure - Grinding Method

1. Clean the area.
2. Insert the appropriate Ball Mill or Abrasive Bit into the hand piece of the Micro-Drill. Gently grind away the coating as needed. (See Table 1 and Figure 2, 3 and 4.)

Caution

Do not exert excessive pressure. Move the bit from side to side to avoid damage to the underlying surface.

3. Remove all loose material and clean the area.

Skill Level: Advanced
Conformance Level: High

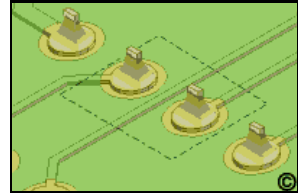

Coating Removal Required At Outlined Area

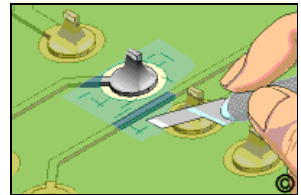

Figure 1: Scrape away damaged or unwanted coating with a Knife, Pick, or Scraper.

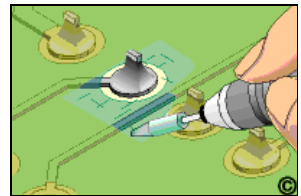

Figure 2: Rubberized abrasives are used to remove thin hard coatings.

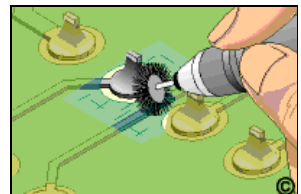
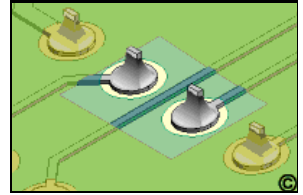

Figure 3: Rotary brushes are used to remove soft coatings or on contoured surfaces.

Table 1 - Abrasive Tip Selector

Part No.	Description	Application
115-6025	Ball Mill, .019" Dia.	Remove thin coatings from small confined areas.
115-6050	Ball Mill, .027" Dia.	
115-6002	Ball Mill, .039" Dia.	
115-6003	Ball Mill, .047" Dia.	
115-6004	Ball Mill, .055" Dia.	
115-6005	Ball Mill, .063" Dia.	
115-6006	Ball Mill, .071" Dia.	
115-6007	Ball Mill, .083" Dia.	
115-6008	Ball Mill, .090" Dia.	
110-4602	Abrading Tip	Remove thin hard coatings from flat surfaces.
-----	Rotary Brush	Remove soft coatings, and coatings from contoured surfaces.

*Figure 4: Removal complete.***Caution**

Ball mills will remove coatings quickly, observe caution.

Evaluation

1. Visual examination or UV light may be used to verify complete removal of coating.

Coating and Solder Mask Repair

Outline

This procedure is used to repair damaged coatings and solder mask on circuit boards. There are so many solder masks and coatings available that it is difficult to always have the exact replacement available. Thus this procedure describes the use of general purpose high strength Epoxy mixed with color agents to replace damaged solder mask and coatings.

This high strength, clear Epoxy is supplied in a unique 2 part package. You always have the proper ratio of hardener and resin. Sounds simple, matching colors and textures precisely requires experience.

IPC Reference*

2.4.1 Coating Replacement, Solder Mask

Kits/Systems

Part No.	Description
201-3110	Base Board Repair Kit (See page 24)
201-2100	Professional Kit (See page 2)

Tools/Materials

Part No.	Description
-----	Brushes
-----	Cleaner
-----	Color Agents (See page 28)
115-3302	Epoxy (See page 26)
235-2102	Foam Swabs
355-2102	Knife
115-3314	Mixing Sticks
115-3312	Plastic Cups
115-3360	Plastic Probe
950-4508	Tape, Kapton
-----	Wipes
Optional Items	
-----	Microscope
-----	Oven
115-1414	Pick
115-1416	Scraper
115-3902	Syringe Assemblies

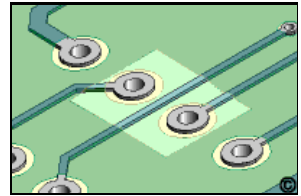

**Coating or Soldermask
Required At Outlined Area**

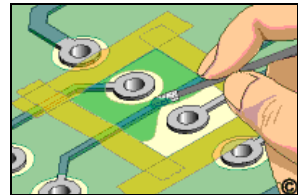

Figure 1: Foam Swabs can be used to create texture.

Procedure

1. Clean the area.

Note

Surfaces to be coated must be thoroughly cleaned prior to coating to ensure adequate adhesion.

2. If needed, apply Tape to outline the area where the coating will be applied.
3. If needed, preheat the circuit board to improve absorption of the Epoxy.
4. Mix a package of Epoxy per instructions on page 26.

Note

For some applications it may be desirable to apply Color Agent directly to the circuit board surface and overcoat it with clear Epoxy.

5. Apply the mixed Epoxy using a Brush, Foam Swab, Pick, or Syringe Assembly. (See Figure 1).
6. Cure the Epoxy per instructions on page 26.

Evaluation

1. Visual examination for texture, color match, adhesion and coverage of coating.
2. Electrical tests to conductors around the coated area as applicable.

Delamination/Blister Repair

Outline

This procedure is used to repair mechanical or thermal blisters or delaminations in circuit board laminated base materials. The blister is sealed by injecting Epoxy into the blister/delamination void.

Note

This method can only be used when the laminate base material has separated sufficiently to allow the Epoxy to flow throughout the delaminated area.

IPC Reference*

3.1 Delamination/Blister Repair

Kits/Systems

Part No.	Description
201-3110	Base Board Repair Kit (See page 24)
201-2100	Professional Kit (See page 2)

Tools/Materials

Part No.	Description
115-6025	Ball Mill, .019" Diameter
-----	Cleaner
	Dispensers
115-3302	Epoxy (See page 26)
110-4102	Micro-Drill System
115-3138	Mill Handle
115-3312	Plastic Cups
115-3314	Mixing Sticks
355-2102	Knife
-----	Oven
115-3902	Syringe Assemblies
950-4508	Tape, Kapton
-----	Wipes
	Optional Items
-----	Microscope

Procedure

1. Clean the area.
2. Mount a small Ball Mill into the hand piece of the Micro-Drill or into the Mill Handle. Drill in an area clear of circuitry or components. Drill at least two holes opposite each other around the perimeter of the delamination. (See Figure 1). Remove all loose material.

Skill Level: Advanced
Conformance Level: High

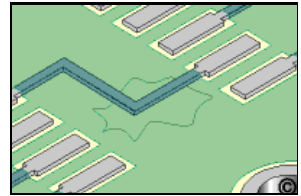

Delamination

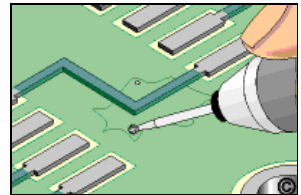

Figure 1: Drill into the delamination blister using a Ball Mill and a Micro-Drill.

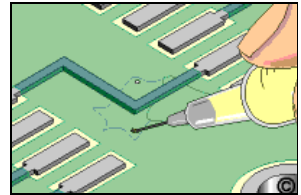

Figure 2: Inject Epoxy into the delamination blister using a Syringe Assembly.

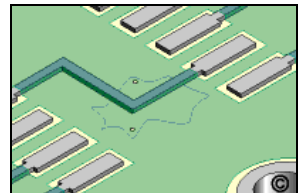

Figure 3: Completed repair.

Caution

Be careful not to drill too deep exposing internal circuits or planes.

3. Bake the circuit board in an oven for 1 hour at 165° F (74° C) to remove any entrapped moisture. Do not allow the circuit board to cool prior to injecting the Epoxy.
4. Mix up a package of Epoxy per instructions on page 30. Follow instruction for mixing the Epoxy without bubbles.
5. Pour the Epoxy into a Syringe Assembly.
6. Inject the Epoxy into one of the holes in the delaminated area. (See Figure 2). The heat retained in the circuit board will improve the flow characteristics of the Epoxy and should draw the Epoxy into the void area filling it completely.
7. If the void does not fill completely, the following procedures may be used:
 - A. Apply light local pressure on the circuit board surface starting at the fill hole, slowly proceeding to the vent hole.
 - B. Apply vacuum to the vent hole to draw the Epoxy through the void.
8. Cure the Epoxy in an oven for 1 hour at 165° F (74° C).
9. After the Epoxy has cured scrape away any excess using a Knife.

Note

If needed, apply additional thin coating to seal any scrapped areas.

Evaluation

1. Visual examination for texture and color match.
2. Electrical tests to conductors around the repaired area as applicable.

Hole Repair, Epoxy Method

Skill Level: Advanced

Conformance Level: High

Outline

This procedure is used to repair minor damage to an unsupported tooling or mounting hole. This repair method uses high strength Epoxy to restore the damaged surface surrounding the hole.

IPC Reference*

3.3.1 Hole Repair, Epoxy Method

Kits/Systems

Part No.	Description
201-3110	Base Board Repair Kit (See page 24)
201-2100	Professional Kit (See page 2)

Tools/Materials

Part No.	Description
-----	Ball Mills, Various Sizes
-----	Cleaner
115-3302	Epoxy (See page 26)
355-2102	Knife
110-4102	Micro-Drill System (See page 31)
115-3314	Mixing Sticks
115-3312	Plastic Cups
115-3360	Plastic Probe
950-4508	Tape, Kapton
-----	Wipes
Optional Items	
-----	Microscope
-----	Oven

Procedure

1. Clean the area.
2. Mount a Ball Mill into the hand piece of the Micro-Drill. Mill away the damaged board base material. No fibers of laminate material should be exposed at the surface perimeter of the hole. (See Figure 1)

Note

To clearly see that all damaged material has been removed, flood the area with alcohol or solvent. Damaged internal fibers of the base material will show up clearly.

3. Remove all loose material and clean the area.

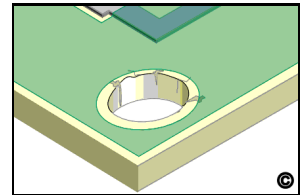

Damaged Hole, Non Plated

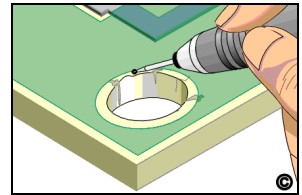

Figure 1: Mill away damaged material with the Micro-Drill and ball mill.

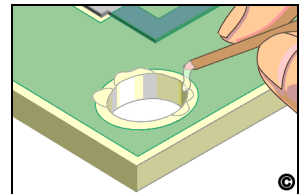

Figure 2: Apply Epoxy with a mixing stick sharpened at one end.

-
4. Where needed, apply Tape to protect exposed parts of the circuit board.

Note

The circuit board may be preheated prior to applying Epoxy. A preheated circuit board will allow the Epoxy to easily flow and level out. Epoxy applied to an unheated circuit board may settle below the circuit board surface as the Epoxy cures.

5. Mix a package of Epoxy per the instructions on page 30. If desired, add a Color Agent to the mixed Epoxy to match the circuit board color.

6. Apply the Epoxy up to and flush with the circuit board surface. A Mixing Stick or Plastic Probe may be used to apply and spread the Epoxy. (See Figure 2).

Note

A slight overfill of Epoxy may be desired to allow for shrinkage when the Epoxy cures.

7. Cure the Epoxy in an oven for 1 hour at 165° F (74° C) or at room temperature for 24 hours.
8. After the Epoxy has cured, remove any tape. If needed, use a Knife or Scraper and scrape off any excess Epoxy. Scrape until the new Epoxy surface is level with the surrounding circuit board surface.
9. Remove all loose material. Clean the area.

Evaluation

1. Visual examination for texture and color match.
2. Hole size measurement to specification.
3. Electrical tests to conductors around the repaired area as applicable.

Hole Repair, Transplant Method

Outline

This procedure is used to repair severe damage to an unsupported tooling or mounting hole, or to modify the size, shape or location of an unsupported tooling or mounting hole. This repair method uses a Rod of matching board material and high strength Epoxy to secure the Rod in place. After the new material is bonded in place a new hole can be drilled.

IPC Reference*

3.3.2 Hole Repair, Transplant Method

Kits/Systems

Part No.	Description
201-3110	Base Board Repair Kit (See page 24)
201-2100	Professional Kit (See page 2)

Tools/Materials

Part No.	Description
-----	Ball Mills, Various Sizes
-----	Cleaner
-----	Drill Bits, Various Sizes
-----	Drill Press
-----	End Mills, Various Sizes
115-3302	Epoxy (See page 30)
115-3132	File
355-2102	Knife
110-4102	Micro-Drill System (See page 31)
115-3312	Plastic Cups
115-3360	Plastic Probes
115-3314	Mixing Sticks
-----	Rod, FR4, Various Sizes
355-4235	Saw
950-4508	Tape, Kapton
-----	Wipes
Optional Items	
-----	Microscope
-----	Oven

Procedure

1. Clean the area.
2. Drill out the damaged or improperly sized hole using a Drill Press fitted with the proper size Drill Bit or End Mill. All damaged base board material must be removed. No fibers of laminate material should be exposed at the surface perimeter

Skill Level: Expert
Conformance Level: High

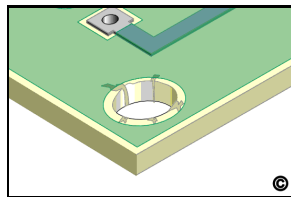

Damaged Hole, Non Plated

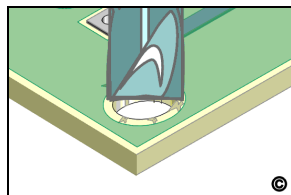

Figure 1: Mill new hole to encompass entire damaged area.

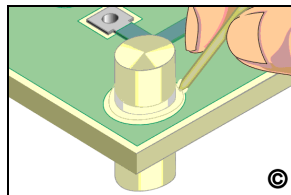

Figure 2: Place replacement dowel in position and bond with Epoxy.

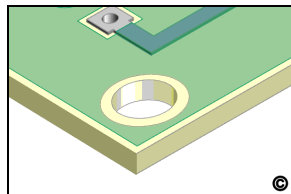

Figure 3: Cut off excess material and redrill holes as required.

of the hole. The diameter of the drilled hole must match the diameter of the replacement Rod of FR4 laminate material to be inserted. (See Figure 1).

Note

To clearly see that all damaged material has been removed, flood the area with alcohol or solvent. Damaged internal fibers of the base material will show up clearly.

3. Remove all loose material and clean the area.
4. Cut a piece of replacement Rod material. Cut the length approximately 12.0 mm (0.50") longer than needed.
5. Protect exposed parts of the circuit board with Tape.
6. Mix a package of Epoxy per the instructions on page 26.

Note

The circuit board may be preheated prior to applying Epoxy. A preheated circuit board will allow the Epoxy to easily flow and level out. Epoxy applied to an unheated circuit board may settle below the circuit board surface as the Epoxy cures.

7. Coat both the Rod and the hole with Epoxy and fit together. Apply additional Epoxy around perimeter of Rod. (See Figure 2). Remove excess Epoxy.
8. Cure the Epoxy in an oven for 1 hour at 165° F (74° C) or at room temperature for 24 hours.
9. Remove Tape and cut off the excess Rod using the Saw. Mill or file the Rod flush with the board surface. (See Figure 3).
10. Complete by drilling holes and adding circuitry as required.
11. Clean the reworked area.

Evaluation

1. Visual and dimensional examination of the reworked area for conformance to drawings and specifications.

Base Board Repair, Epoxy Method

Skill Level: Advanced
Conformance Level: High

Outline

This procedure is used to repair minor damage to circuit base board material including scrapes, scratches and burns.

Caution

This procedure should not be used when the damage extends deep into the base material.

Caution

Surface circuits may need to be replaced in the damaged area. Be sure that the appropriate circuit diagrams, or photographs reflecting the original circuits are available so that they may be replaced after repairing the base board material.

IPC Reference*

3.5.1 Base Materials Repair, Epoxy Method

Kits/Systems

Part No.	Description
201-3110	Base Board Repair Kit (See page 24)
201-2100	Professional Kit (See page 2)

Tools/Materials

Part No.	Description
-----	Ball Mills, Various Sizes
-----	Cleaner
-----	Color Agent, Various Colors (See page 28)
115-3302	Epoxy (See page 26)
235-2102	Foam Swabs
355-2102	Knife
110-4102	Micro-Drill System (See page 31)
115-3314	Mixing Sticks
115-3312	Plastic Cups
115-3360	Plastic Probes
115-1416	Scraper
950-4508	Tape, Kapton
-----	Wipes
Optional Items	
-----	Microscope
-----	Oven

Procedure

1. Clean the area.

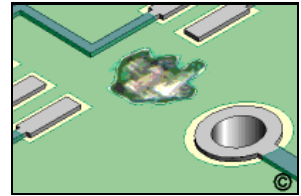

Damaged Base Material

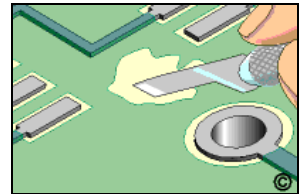

Figure 1: Scrape away damaged base board material with a Knife or Micro-Drill.



Figure 2: The Micro-Drill System is ideal for precision grinding to remove damage.

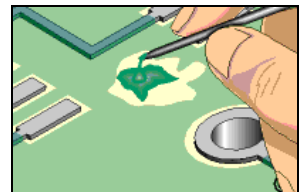

Figure 3: Epoxy can be applied with a Plastic Probe or Mixing Stick sharpened at the end.

2. Scrape away the damaged base board material using a knife or Micro-Drill fitted with a Ball Mill. All damaged base board material and solder mask must be removed at the surface. (See Figure 1).

Note

To clearly see that all damaged material has been removed, flood the area with alcohol or solvent. Damaged internal fibers of the base material will show up clearly.

3. Remove all loose material and clean the area.
4. If needed apply Tape to protect exposed parts of circuit board.
5. Mix a package of Epoxy per the instructions on page 26.

Note

The circuit board may be preheated prior to applying Epoxy. A preheated circuit board will allow the Epoxy to easily flow and level out. Epoxy applied to an unheated circuit board may settle below the circuit board surface as the Epoxy cures.

6. Fill the area with Epoxy up to and flush with the circuit board surface. No fibers of laminate material should be exposed. A Mixing Stick or Plastic Probe may be used to apply and spread the Epoxy. For large areas, apply the Epoxy with a foam swab to create a texture in the surface. (See Figures 3 and 4).

Note

A slight overfill of Epoxy may be desired to allow for shrinkage when Epoxy cures.

7. Cure the Epoxy in an oven for 1 hour at 165° F (74° C) or at room temperature for 24 hours.
8. After the Epoxy has cured remove the tape.
9. If needed, use a knife or scraper and scrape off any excess Epoxy. Scrape until the new Epoxy surface is level with the surrounding circuit board surface.
10. Remove all loose material. Clean the area.

Evaluation

1. Visual examination for texture and color match.
2. Electrical tests to conductors around the repaired area as applicable.

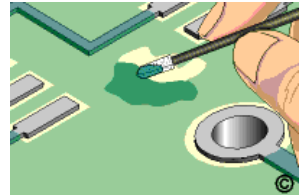

Figure 4: A foam swab can be used to create a texture in the surface.

Base Board Repair, Edge Transplant

Outline

This procedure is used to repair major damage to the edges of of circuit base board material. This procedure is used when extended areas of base material must be completely replaced.

Caution

Surface circuits may need to be replaced in the damaged area. Be sure that the appropriate circuit diagrams, or photographs reflecting the original circuits are available so that they may be replaced after repairing the base board material.

IPC Reference*

3.5.3 Base Materials Repair, Epoxy Method

Kits/Systems

Part No.	Description
201-3110	Base Board Repair Kit (See page 24)
201-2100	Professional Kit (See page 2)

Tools/Materials

Part No.	Description
-----	Ball Mills, Various Sizes
-----	Base Board Transplants
-----	Cleaner
-----	Color Agent, Various Sizes (See page 28)
115-3302	Epoxy (See page 26)
115-3132	File
235-2102	Foam Swab
355-2102	Knife
110-4102	Micro-Drill System (See page 31)
115-3314	Mixing Sticks
115-3312	Plastic Cups
235-4235	Saw
115-1416	Scraper
950-4508	Tape, Kapton
-----	Wipes

Optional Items

-----	Slotting Saw Bit
-----	Drill Press
-----	Microscope
-----	Oven

Procedure

1. Clean the area.

Skill Level: Expert
Conformance Level: High

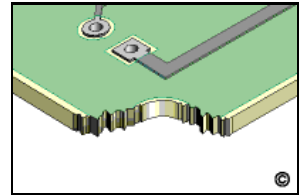

Damaged Base Material

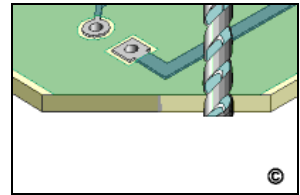

Figure 1: Cut away damaged base board material.

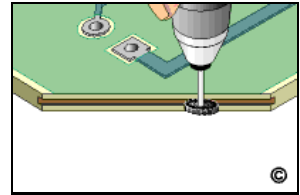

Figure 2: Cut a groove into the edge of the board with a Saw or Slotting Saw Bit.

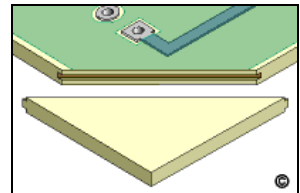

Figure 3: Check fit of new base material. The tongue must mate with the groove.

2. Cut away the damaged board material using the Saw. Remove all damaged material. No fibers of the base material should be exposed. File the edge to create a smooth flat surface. (See Figure 1).

Note

To clearly see that all damaged material has been removed, flood the area with alcohol or solvent. Damaged internal fibers of the base material will show up clearly.

Caution

Exercise care to avoid damage to any internal conductors. If any internal conductors are damaged, surface wires may be required to restore electrical connection.

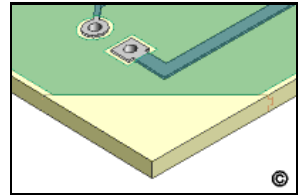

Figure 4: Saw off excess new base material.

3. Clean the area.

- 4A. Cut a groove into the edge of the circuit board using the saw. Center the cut on the thickness of the circuit board and cut into the edge .040" (1.00 mm) deep.

or

- 4B. Install a Slotting Saw Bit into the Micro-Drill System. Set the speed to maximum and machine a groove in the edge of the circuit board. Center the cut on the thickness of the circuit board and cut into the edge .040" (1.00 mm) deep. (See Figure 2).

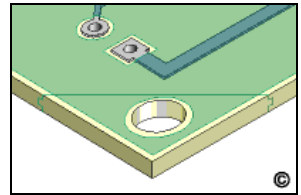

Figure 5: Complete by drilling holes or adding circuitry and coatings as needed.

5. Select a section of Base Board Transplant material that is the same thickness as the circuit board. Cut the length as needed.
6. Check the fit to be sure the new base material properly mates with the groove in the circuit board. (See Figure 3).
7. Where required apply Tape to protect exposed parts of circuit board.

8. Mix a package of Epoxy per the instructions on page 30.

Note

The circuit board may be preheated prior to applying Epoxy. A preheated circuit board will allow the Epoxy to easily flow and level out. Epoxy applied to an unheated circuit board may settle below the circuit board surface as the Epoxy cures.

9. Coat both the tongue in the Base Board Transplant and the groove in the edge of the circuit board with Epoxy and fit together. Remove excess Epoxy.

10. Cure the Epoxy in an oven for 1 hour at 165° F (74° C) or at room temperature for 24 hours.
11. After the Epoxy has cured remove the Tape.
12. If needed, use a Knife or Scraper and scrape off any excess Epoxy. Scrape until the new Epoxy surface is level with the surrounding circuit board surface.
13. Saw off the excess Base Board Transplant material. File flush with existing edge. (See Figure 4).
14. Clean the area.
15. Complete by drilling holes, slots, etc. or adding circuitry as required. (See Figure 5).
16. If needed, replace solder mask or coatings. (See Figure 5).

Evaluation

1. Dimensions of area replaced should be checked to conform to specifications required.

Lifted Conductor Repair

Outline

This procedure is used to repair damaged and lifted conductors. Bonding Film or liquid Epoxy is used to rebond the conductor.

Caution

This method should not be used to rebond a conductor that has been stretched or damaged.

IPC Reference*

- 4.1.1 Lifted Conductor Repair, Epoxy Method
- 4.1.2 Lifted Conductor Repair, Film Adhesive Method

Tools and Materials

Part No.	Description
201-3110	Base Board Repair Kit (See page 24)
201-2100	Professional Kit (See page 2)

Tools/Materials

Part No.	Description
115-2706	Bonding Film
115-3102	Bonding Iron, 120 VAC
-----	Bonding Tips, Various Sizes
-----	Cleaner
115-3302	Epoxy (See page 26)
355-2102	Knife
115-3314	Mixing Sticks
115-3312	Plastic Cups
115-1416	Scraper
950-4508	Tape, Kapton
335-5183	Tweezers
-----	Wipes

Optional Items

115-3118	Circuit Bonding System
-----	Microscope
-----	Oven

Procedure - Bonding Film Method

1. Clean the area.

Caution

Be careful not to stretch or damage the lifted conductor.

2. Cut out a piece of Bonding Film and place it under the section of lifted conductor. (See Figure 1).

Skill Level: Intermediate
Conformance Level: High

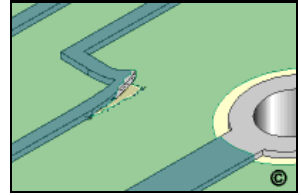

Lifted Conductor

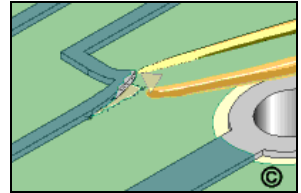

Figure 1: Cut out a piece of Bonding Film and place it under the lifted conductor.

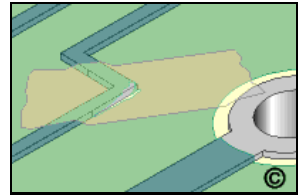

Figure 2: Place Kapton Tape over the lifted conductor.



Figure 3: Bond the lifted conductor using a Bonding Iron or Circuit Bonding System.

3. Select a Bonding Tip with a shape to match the shape of the lifted conductor and insert it into the Bonding Iron or Circuit Bonding System. Allow in the Bonding Iron or Circuit Bonding System 10 minutes to warm up.

Note

The Bonding Tip should be as small as possible but should completely cover the entire surface of the conductor.

4. Place a piece of Kapton Tape over the lifted conductor. (See Figure 2).
5. Position the circuit board so that it is flat and stable. Gently place the hot Bonding Tip onto the tape covering the conductor. Apply light downward pressure for 5 seconds to tack the lifted conductor back in place.
6. Remove the Tape and gently place the Bonding Tip directly onto the conductor. Apply light downward pressure for 30 seconds to bond the lifted conductor back in place.
7. Carefully clean the area and inspect the conductor.
8. Replace surface coating to match prior coating as required.

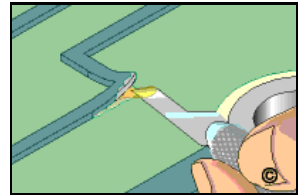

Figure 4: Apply a small amount of Epoxy under the length of the lifted conductor.

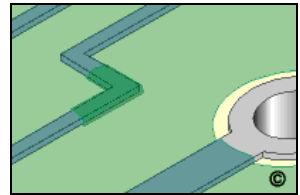

Figure 5: Completed repair.

Procedure - Epoxy Method

1. Clean the area.

Caution

Be careful not to stretch or damage the lifted conductor.

2. Mix a package of Epoxy per the instructions on page 30.

Note

The circuit board may be preheated prior to applying Epoxy. A preheated circuit board will allow the Epoxy to easily flow and level out. Epoxy applied to an unheated circuit board may settle below the circuit board surface as the Epoxy cures.

3. Carefully apply a small amount of Epoxy under the length of the lifted conductor. Flatten the conductor in place. A Knife or Probe may be used to apply the Epoxy. (See Figure 4).
4. Cure the Epoxy in an oven for 1 hour at 165° F (74° C) or at room temperature for 24 hours.

5. Clean the area and replace surface coating to match prior coating as required.

Evaluation

1. Visual examination and electrical tests as applicable.

Conductor Repair, Foil Jumper

Outline

This procedure is used on circuit boards to replace damaged or missing conductors on the circuit board surface.

Caution

The conductor widths, spacing and current carrying capacity must not be reduced below allowable tolerances.

IPC Reference*

4.2.1 Conductor Repair, Foil Jumper Method

Kits/Systems

Part No.	Description
201-3130	Circuit Track Kit (See page 17)
201-2100	Professional Kit (See page 2)

Tools/Materials

Part No.	Description
-----	Circuit Tracks, See Table Below
-----	Cleaner
-----	Color Agent, Various Colors (See page 28)
115-3302	Epoxy (See page 26)
115-3110	Eraser
-----	Flux
355-2102	Knife
115-3314	Mixing Sticks
115-3312	Plastic Cups
115-1416	Scraper
-----	Solder
-----	Soldering Iron w/Tips
950-4508	Tape, Kapton
335-5183	Tweezers
-----	Wipes

Optional Items

-----	Microscope
-----	Oven

Procedure - Bonding Film Method

1. Clean the area.
2. Remove the damaged section of circuit using a knife. The damaged circuit should be trimmed back to a point where the circuit still has a good bond to the circuit board surface.

Skill Level: Intermediate
Conformance Level: High

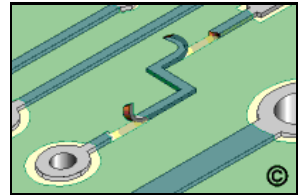

Damaged Conductor

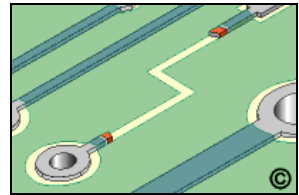

Figure 1: Scrape off any solder mask or coating from the ends of the remaining circuits.

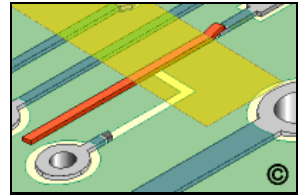

Figure 2: Place the new Circuit Track in position and hold in place with Tape.

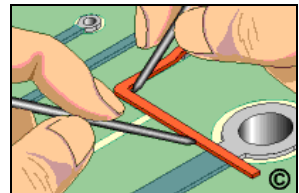

Figure 3: Bend Circuit Track using 2 wood sticks.

Note

Heat can be applied to the damaged circuit using a soldering iron to allow the circuit to be removed more easily.

3. Use a knife and scrape off any solder mask or coating from the ends of the remaining circuit. (See Figure 1)
4. Remove all loose material. Clean the area.
5. Apply a small amount of liquid flux to the ends of the remaining circuit. Tin the exposed end of each circuit using Solder and a Soldering Iron.
6. Clean the area.
7. Select a Circuit Track to match the width and thickness of the conductor to be replaced. (See Table Below) Cut a length approximately as needed. The Circuit Track should overlap the existing circuit a minimum of 2 times the circuit width.

Table 1 - Circuit Track Sizes

Part No.	Description
115-5204	Circuit Track, .002" x .004"
115-5206	Circuit Track, .002" x .006"
115-5208	Circuit Track, .002" x .008"
115-5210	Circuit Track, .002" x .010"
115-5312	Circuit Track, .003" x .012"
115-5315	Circuit Track, .003" x .015"
115-5520	Circuit Track, .005" x .020"
115-5530	Circuit Track, .005" x .030"

8. Gently abrade the top and bottom surface of the Circuit Track with an Eraser to remove any oxidation. Clean the Circuit Track.
9. If needed, the ends of the Circuit Track may be tinned with solder prior to lap soldering it in place.
10. If the Circuit Track is long or has bends, one end may be soldered prior to forming the new shape. Place the Circuit Track in position. The Circuit Track should overlap the existing circuit a minimum of 2 times the conductor width. The Circuit Track may be held in place with Kapton Tape. (See Figure 2).

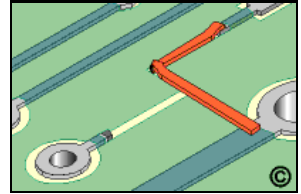

Figure 4: Wide Circuit Tracks may be folded over to produce a sharp bend.

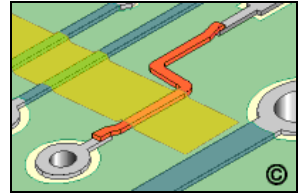

Figure 5: Form the shape of the Circuit Track and hold in place with Tape.

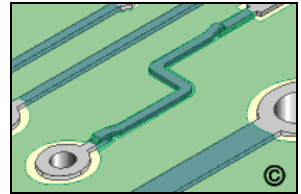

Figure 6: Coat the top and sides of the Circuit Track with Epoxy.

11. Apply a small amount of liquid flux to the overlap joint. Lap solder the Circuit Track to the conductor on the circuit board surface. Make sure the Circuit Track is properly aligned.

12. Bend the Circuit Track as needed to match the shape of the missing circuit. (See Figure 3).

Note

Two Wood Sticks can be used to make sharp bends in the replacement Circuit Track. Use one Wood Stick to hold the Circuit Track at the bend location and use the other Wood Stick to form the shape as needed.

Note

Wide Circuit Tracks that cannot be easily formed may be folded over to produce a sharp bend. (See Figure 4).

13. Form the final shape of the Circuit Track and hold in place with Tape. Lap solder the Circuit Track to the remaining conductor on the circuit board. Make sure the Circuit Track is properly aligned. Remove the Tape used to hold the Circuit Track and clean the area. (See Figure 5).

14. Mix a package of Epoxy per the instructions on page 26.

Note

The circuit board may be preheated prior to applying Epoxy. A preheated circuit board will allow the Epoxy to easily flow and level out. Epoxy applied to an unheated circuit board may settle below the circuit board surface as the Epoxy cures.

15. Coat the top and sides of the Circuit Track with Epoxy. A Wood Stick or Plastic Probe may be used to apply the Epoxy. (See Figure 6).

16. Cure the Epoxy in an oven for 1 hour at 165° F (74° C) or at room temperature for 24 hours.

17. Apply surface coating to match prior coating as required.

Evaluation

1. Visual examination for alignment and overlap of Circuit Track.

2. Electrical tests as applicable.

Circuit Cuts

Outline

This procedure is used to eliminate a short or to cut circuits on a circuit board. A small section of the circuit is removed forming a break. The width of the break should be at least as wide as the minimum conductor spacing.

IPC Reference*

4.3.1 Circuit Cut, Surface Circuits

Kits/Systems

Part No.	Description
110-4102	Micro-Drill System (See page 31)

Tools/Materials

Part No.	Description
-----	Ball Mills, Various Sizes
-----	Cleaner
-----	Color Agent, Various Colors (See page 28)
-----	Continuity Meter
115-3302	Epoxy
355-2102	Knife
115-3314	Mixing Sticks
110-4102	Micro-Drill System (See page 31)
115-3312	Plastic Cups
950-4508	Tape, Kapton
-----	Wipes
Optional Items	
-----	Microscope
-----	Oven

Procedure

1. Identify the circuit or short to be cut. Determine from the artwork or drawings where the best location is to make the cut. The width of the cut should at least match the minimum required electrical spacing.
2. Clean the area.
3. Carefully make two small cuts with the Knife and remove the short section of circuit. (See Figure 1).

OR

4. Select the appropriate size Ball Mill and insert it into the hand piece of the Micro-Drill System. Set the speed to high. (See

Skill Level: Intermediate
Conformance Level: High

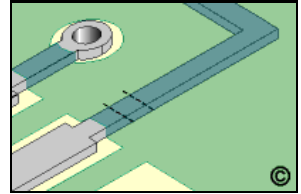

Circuit Cut, Surface Circuit

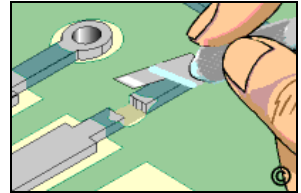

Figure 1: Make two small cuts with a Knife and remove a short section of circuit.



Figure 2: The Micro-Drill System is ideally suited for delicate circuit cuts.

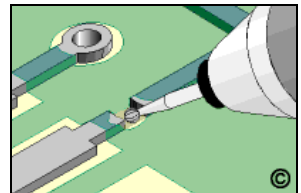

Figure 3: Make 1 or 2 cuts as needed using a Ball Mill and Micro-Drill.

Figure 2). The Ball Mill should be approximately the same width as the circuit to be cut.

- Carefully make 1 or 2 cuts as needed. (See Figure 3)

Caution

Exercise care to avoid damage to adjoining circuits.

- Check continuity to be sure that the circuit has been cut.

- Clean the area.

- Mix a package of Epoxy per the instructions on page 26.

Note

The circuit board may be preheated prior to applying Epoxy. A preheated circuit board will allow the Epoxy to easily flow and level out. Epoxy applied to an unheated circuit board may settle below the circuit board surface as the Epoxy cures.

- Seal the cut with Epoxy. A Wood Stick, Plastic Probe, or Syringe Assembly may be used to apply the Epoxy.

- Cure the Epoxy in an oven for 1 hour at 165° F (74° C) or at room temperature for 24 hours.

Evaluation

- Visual examination of circuit cut for proper spacing, and visual examination of surrounding circuits for any damage.
- Electrical tests as applicable.

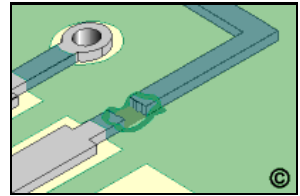

Figure 4: Completed repair.

Land Repair

Outline

This procedure is used to replace damaged and missing lands. The damaged lands are replaced with new dry film, adhesive backed lands. The new lands are bonded to the circuit board surface using a Bonding Iron or Circuit Bonding System.

Caution

This method is used to replace a damaged or missing land, but the new land will not have an intermetallic connection to the remaining plated hole. The solder joint of the replaced component will restore the integrity of the electrical connection.

IPC Reference*

4.5.2 Land Repair, Film Adhesive Method

Kits/Systems

Part No.	Description
201-1110	Land Repair Kit (See page 9)
201-2100	Professional Kit (See page 2)

Tools/Materials

Part No.	Description
	Ball Mills, Various Sizes
115-3102	Bonding Iron, 120 VAC
-----	Bonding Tips, Various Sizes
-----	Circuit Frames, Various (See page 15)
-----	Cleaner
115-3302	Epoxy (See page 26)
-----	Flux
355-2102	Knife
115-3314	Mixing Stick
115-3312	Plastic Cup
115-3360	Plastic Probe
-----	Solder
-----	Soldering Iron
950-4508	Tape, Kapton
335-5183	Tweezer
Optional Items	
115-3118	Circuit Bonding System
-----	Microscope
-----	Oven

Skill Level: Advanced
Conformance Level: High

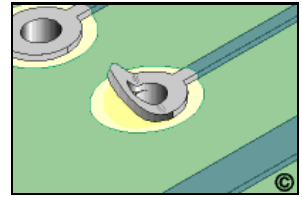

Damaged Land

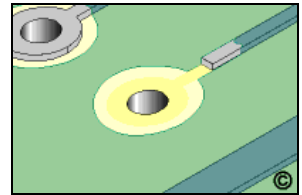

Figure 1: Remove the defective land and soldermask from the connecting circuit.

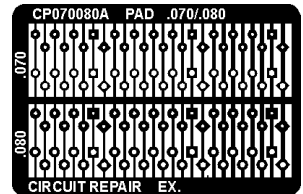

Figure 2: Select a replacement land that matches the missing land.

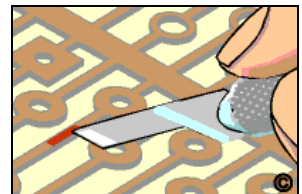

Figure 3: Scrape off the bonding film from solder joint area on the back side.

Procedure

1. Remove the defective land and a short length of the connecting circuit, if any. (See Figure 1)
2. Scrape off any residue, contamination or burned material from the board surface.
3. Scrape off any solder mask or coating from the connecting circuit and clean the area. (See Figure 1).
4. Apply a small amount of liquid flux to the connection area on the circuit board surface and tin with solder. Clean the area. The length of the overlap solder connection should be a minimum of 2 times the circuit width.
5. The area for the new pad on the board surface must be smooth and flat. If internal fibers of the board are exposed or if there are deep scratches in the surface they should be repaired. (See Base Board Repair procedure on page 54)
6. Select a replacement land that most closely matches the size and shape of the missing land. (See Figure 2).
7. Before trimming out the new land carefully scrape off the bonding film from the solder joint connection area on the back side. (See Figure 3).

Caution

Scrape off the bonding film only from the joint connection area. When handling the new land avoid touching the bonding film to prevent contamination that may reduce the bond strength.

8. Cut out and trim the new land. Cut out from the plated side. Cut the length to provide the maximum allowable circuit overlap for soldering. Minimum 2 times the circuit width. (See Figure 4).
9. Place a piece of Kapton Tape over the top surface of the new land. Place the new land in position on the circuit board surface using the Kapton Tape to aid in alignment.
10. Select a Bonding Tip to match the shape of the new land and insert it into the Bonding Iron or Circuit Bonding System. Allow in the Bonding Iron or Circuit Bonding System 10 minutes to warm up.

Note

The Bonding Tip should be as small as possible but cover the entire surface of the new land.

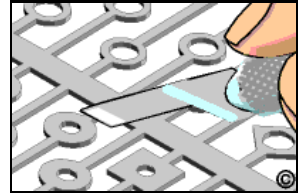

Figure 4: Cut out the new land. Cut from the plated side.

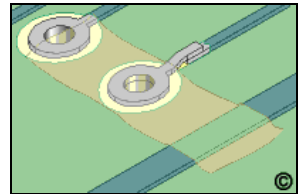

Figure 5: Place the new land in position using Kapton Tape.



Figure 6: Bond the new land with a Bonding Iron or Circuit Bonding System.

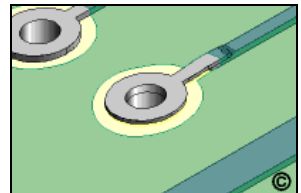

Figure 7: Completed land repair.

- 11 Position the circuit board so that it is flat and stable. Gently place the hot Bonding Tip onto the tape covering the new land. Apply light downward pressure for 5 seconds to tack the new land in place. (See Figure 6).
12. Carefully peel off the Tape. Gently place the Bonding Tip directly onto the new land. Apply light downward pressure for an additional 30 seconds to fully bond the new land.
13. Inspect the new land for proper alignment.
14. If the new land has a connecting circuit apply a small amount of liquid flux to the lap solder joint connection area and solder the circuit from the new land to the circuit on the circuit board surface.
15. Mix a package of Epoxy per the instructions on page 26.
Note
The circuit board may be preheated prior to applying Epoxy. A preheated circuit board will allow the Epoxy to easily flow and level out.
16. Coat the lap solder joint connection with Epoxy. A Wood Stick, Plastic Probe, or Syringe Assembly may be used to apply the Epoxy.
Note
Additional Epoxy can be applied around the perimeter of the new pad to provide additional bond strength.
17. Cure the Epoxy in an oven for 1 hour at 165° F (74° C) or at room temperature for 24 hours.
18. Carefully remove any excess bonding film inside the plated hole using ball mill. Turn the Ball Mill by hand to prevent damage to the wall of the plated through hole.
19. Install the proper component and solder in place.
Note
The new land will not have an intermetallic connection to the plated hole. The solder joint of the replaced component will restore the integrity of the electrical connection or an eyelet or buss wire may be used. (See Plated Hole Repair Procedure on page 79)

Evaluation

1. Visual examination of new land width and spacing and electrical continuity measurement.

Gold Contact Repair

Skill Level: Advanced
Conformance Level: High

Outline

This procedure is used to replace damaged and missing gold edge contacts. The damaged gold contacts are replaced with new dry film, adhesive backed contacts. The new edge contacts are bonded to the circuit board surface using a Bonding Iron or Circuit Bonding System.

Note

Replacement gold edge contacts are available already nickel and gold plated to eliminate subsequent electroplating.

IPC Reference*

4.6.2 Edge Contact Repair, Film Adhesive Method

Kits/Systems

Part No.	Description
201-1120	Gold Contact Repair Kit (See page 7)
201-2100	Professional Kit (See page 2)

Tools/Materials

Part No.	Description
115-3102	Bonding Iron, 120 VAC
-----	Bonding Tips, Various Sizes
-----	Circuit Frames, Various (See page 15)
-----	Cleaner
115-3302	Epoxy (See page 26)
115-3132	File
-----	Flux
355-2102	Knife
115-3314	Mixing Stick
115-3312	Plastic Cup
115-3360	Plastic Probe
-----	Solder
-----	Soldering Iron
950-4508	Tape, Kapton
335-5183	Tweezer

Optional Items

115-3118	Circuit Bonding System
-----	Microscope
-----	Oven

Procedure

1. Remove the defective gold contact and a short length of the connecting circuit, if any. (See Figure 1)

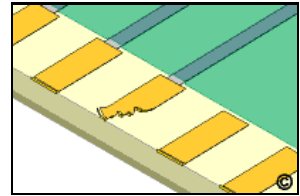

Damaged Gold Edge Contact

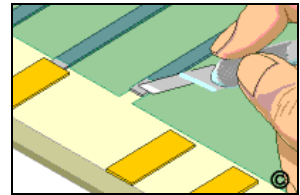

Figure 1: Remove the defective contact and soldermask from the connecting circuit.

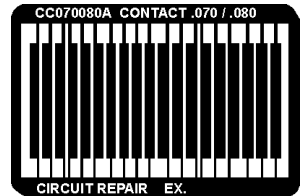

Figure 2: Select a replacement edge contact that matches the missing contact.

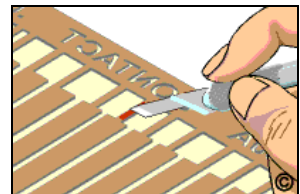

Figure 3: Scrape off the bonding film from solder joint area on the back side.

2. Scrape off any residue, contamination or burned material from the board surface.
3. Scrape off any solder mask or coating from the connecting circuit and clean the area. (See Figure 1).
4. Apply a small amount of liquid flux to the connection area on the circuit board surface and tin with solder. Clean the area. The length of the overlap solder connection should be a minimum of 2 times the circuit width.
5. The area for the new edge contact on the board surface must be smooth and flat. If internal fibers of the board are exposed or if there are deep scratches in the surface they should be repaired. (See Base Board Repair procedure on page 46)
6. Select a replacement edge contact that most closely matches the size and shape of the missing edge contact. (See Figure 2).
7. Before trimming out the new edge contact carefully scrape off the bonding film from the solder joint connection area on the back side. (See Figure 3).

Caution

Scrape off the bonding film only from the joint connection area. When handling the new edge contact avoid touching the bonding film to prevent contamination that may reduce the bond strength.

8. Cut out and trim the new edge contact. Cut out from the plated side. Cut the length to provide the maximum allowable circuit overlap for soldering. Minimum 2 times the circuit width. (See Figure 4).
9. Place a piece of Kapton Tape over the top surface of the new edge contact. Place the new edge contact in position on the circuit board surface using the Kapton Tape to aid in alignment.

Note

Allow the new edge contact to overhang the edge of the circuit board.

10. Select a Bonding Tip to match the shape of the new edge contact and insert it into the Bonding Iron or Circuit Bonding System. Allow in the Bonding Iron or Circuit Bonding System 10 minutes to warm up.

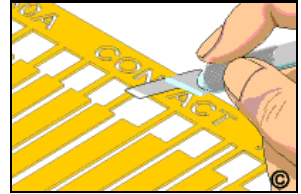

Figure 4: Cut out the new edge contact. Cut from the plated side.

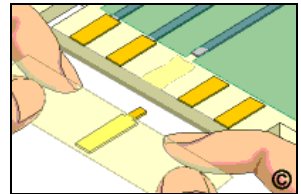

Figure 5: Place the new edge contact in position using Kapton Tape.



Figure 6: Bond the new edge contact with a Bonding Iron or Circuit Bonding System.

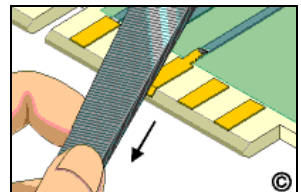

Figure 7: File the overhanging piece of the new edge contact to blend with existing bevel.

Note

The Bonding Tip should be as small as possible but cover the entire surface of the new edge contact.

11. Position the circuit board so that it is flat and stable. Gently place the hot Bonding Tip onto the tape covering the new edge contact. Apply light downward pressure for 5 seconds to tack the new edge contact in place. (See Figure 6).
12. Carefully peel off the Tape. Gently place the Bonding Tip directly onto the new edge contact. Apply light downward pressure for an additional 30 seconds to fully bond the new edge contact.
13. Inspect the new edge contact for proper alignment.
14. Trim the extending edge of the new edge contact with a file. File parallel to the beveled edge until the excess material has been removed. (See Figure 7).
15. If the new edge contact has a connecting circuit apply a small amount of liquid flux to the lap solder joint connection area and solder the circuit from the new edge contact to the circuit on the circuit board surface.
16. Mix a package of Epoxy per the instructions on page 30.

Note

The circuit board may be preheated prior to applying Epoxy. A preheated circuit board will allow the Epoxy to easily flow and level out.

17. Coat the lap solder joint connection with Epoxy. A Wood Stick, Plastic Probe, or Syringe Assembly may be used to apply the Epoxy.

Note

Additional Epoxy can be applied around the perimeter of the new edge contact to provide additional bond strength.

18. Cure the Epoxy in an oven for 1 hour at 165° F (74° C) or at room temperature for 24 hours.

Evaluation

1. Visual examination of new edge contact width and spacing.
2. Electrical continuity measurement.

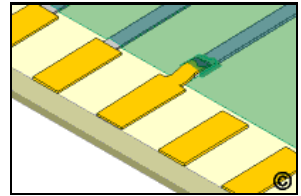

Figure 8: Completed edge contact repair.

Gold Contact Plating

Skill Level: Advanced
Conformance Level: High

Outline

This procedure is used to replate gold edge contacts by selective swab plating. Edge contacts may require replating if they become contaminated with solder or are scratched during handling. Other applications may arise when the plating on the edge contacts does not meet the minimum thickness specification, or if the specification changes.



**Gold Contact
Plating Kit**

This electroplating process uses a DC power supply. One lead is connected to the connector edge contacts that need plating. A second lead is connected to the plating probe. The plating probe has an anode fastened to the tip. The anode has absorbent wrapping. The anode is dipped into high-speed proprietary plating solutions. When the saturated anode is swabbed across the circuit board connector edge contacts, the metal contained in the solution is plated wherever electrical contact is made. Prior to replating any solder contamination must be removed.

Caution

This method can be used to replate any metal surface including connector edge contacts, but it is essential that the surface to be plated is free of deep scratches, nicks, pin holes or other defects. If the edge contacts need to be replaced see page 7.

Safety

A thorough review of this method should be made before repairs are attempted. Technicians should become familiar with the tools included and should practice on scrap circuit boards

To expect the best results a clean work environment is essential. A smooth work surface and good lighting are recommended. Safety glasses and safety gloves should always be worn when handling hazardous chemicals.

The work area should be adequately ventilated. It is particularly important to have adequate ventilation when using gold solution, since gold solution contains a very small percentage of free cyanide. If ventilation is not adequate, use a fan to move fumes away from the operator.

IPC Reference*

4.6.3 Edge Contact Repair, Plating Method

Kits/Systems

<u>Part No.</u>	<u>Description</u>
115-1702	Gold Contact Plating Kit (See page 29)

Tools/Materials

<u>Part No.</u>	<u>Description</u>
115-3702	Abrasive Pad, White
510-2408	Alligator Clip
115-1412	Burnisher
-----	Cleaner
245-1102	Conductive Pen
250-1201	Conformal Coating Remover Pen
-----	Desoldering Braid/Desoldering System
115-3106	Eraser Stick
-----	Flux
235-2192	Foam Swab
-----	Gloves
355-2102	Knife
115-3312	Plastic Cup
115-3722	Plating Anode, Small
115-3721	Plating Anode, Standard
115-3742	Plating Cable, Black
115-3743	Plating Cable, Red
115-3752	Plating Probe, Black
115-3753	Plating Probe, Red
115-3821	Plating Solution, Gold, 1 oz.
115-3831	Plating Solution, Nickel, 1 oz.
115-3841	Plating Solution, Electroclean, 1 oz.
115-3851	Plating Solution, Solder Strip, 1 oz.
-----	Rinse Bottle
-----	Safety Glasses
-----	Solder and Soldering Iron
-----	Tape, Kapton
290-3050	Tape, Plating, 72 yds.
290-7150	Tape, Peel Testing, 60 yds.
-----	Wipes
115-3778	Wire, Buss, 30 AWG
	<u>Optional Items</u>
-----	Microscope
-----	Oven
-----	Thickness Measuring System
-----	Work Sink

Preparation - Remove Solder Contamination

Caution

Safety glasses and safety gloves should always be worn when handling hazardous chemicals. Do not work within a small enclosed room without supplemental ventilation. If ventilation is not adequate, use a fan to move fumes away from the operator.

1. Clean the rework area.
2. Apply Plating Tape to the circuit board surface surrounding the area to be reworked. The Plating Tape will protect adjacent components and the circuit board surface from unwanted exposure to stripping and plating solutions.
3. Flow solder over the entire area of any contacts that have contamination using a soldering iron. This provides a more even surface when plating. Remove the bulk of the solder contamination using desoldering tools or desoldering braid. (See Figure 1)
4. Clean the area.
5. Place the circuit board so that the leading edge overhangs a tray to collect runoff solution.
6. Swab the Solder Stripping solution over the solder contamination using a Foam Swab. Swab the surface until all remaining solder has been stripped off. (See Figure 2)
7. Thoroughly rinse the entire area with water. See Figure 3)
8. Mildly buff the contacts using an Abrasive Pad. Mild buffing will prepare the surface for plating and remove any remaining solder contamination.
9. Thoroughly rinse with water to remove any residue.

Preparation - Remove Surface Defects

1. Clean the rework area.
2. Apply Plating Tape to the circuit board surface surrounding the area to be reworked. The Plating Tape will protect adjacent components and the circuit board surface from unwanted exposure to stripping and plating solutions.
3. Clean the area.
4. Buff the contacts using an Abrasive Pad. Buff the contacts until all defective or poor plating is removed.

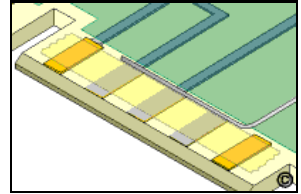

Figure 4: Apply Kapton Tape then solder a wire to the edge of the contacts needing plating.

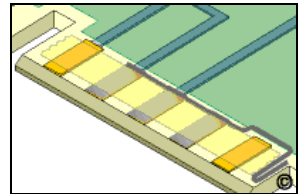

Figure 5: Apply Kapton Tape then apply Conductive Ink to the contacts that need plating.

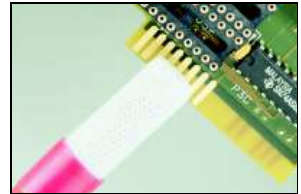

Figure 6: Plating Anodes shown with absorbent wrapping.

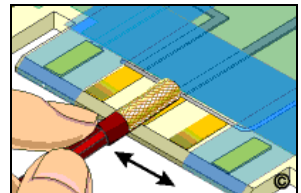

Figure 7: Swab all the contacts by brushing the surface with the saturated plating probe.

5. Burnish small scratches. Use the tip of a Burnisher to work the copper material into the scratch and smooth out the area. Finish by mildly buffing the area to remove any minor burnishing marks. If there are large scratches the contact may need replacement.
6. Thoroughly rinse the entire area with water to remove any residue.

Busing

A conductive bus must be made to all the contacts that need plating. There are 3 basic connection options.

Note

Making a reliable bus connection is the most important step in plating. All sorts of problems will be eliminated by taking the time to make a reliable bus connection.

Busing - Wire Soldered to Edge (Option 1)

Caution

When finished, this method will leave a small unplated line along the inner tip of each contact.

1. Apply Kapton Tape to all the contacts to be plated. The Kapton Tape should cover the entire contact except for a small line along the inboard edge. The Kapton Tape will prevent further solder contamination.
2. Solder a 30 Gauge Wire directly to the inboard tip or connecting circuit of each contact to be plated. The smallest amount of solder should be used to prevent further contamination. (See Figure 4)

Busing - Conductive Ink (Option 2)

Caution

When finished, this method will leave a small unplated line along the inner tip of each contact.

1. Apply Kapton Tape to all the contacts to be plated. The Kapton Tape should cover the entire contact except for a small line along the inboard edge. The Kapton Tape will prevent the Conductive Ink from contaminating the contact surface.
2. Apply a thin coating of conductive ink directly to the inboard tip of each contact to be plated using a Conductive Ink Pen. The conductive ink should extend out to one edge so that a

clip can be applied to make electrical connection. (See Figure 5)

Busing - Mechanical Probe (Option 3)

1. Each contact needing plating can be individually probed using the Plating Probe. Touch the tip of the plating probe to the inboard edge of each contact or to the connecting circuit as each solution is applied during the plating process.

Procedure - Plating Process

1. Place the circuit board so that the leading edge overhangs a tray to collect runoff solution.
2. Make the cathode connection (-) to the circuit board by using a Black Plating Probe or Probe Clip. Connect the Probe Clip directly to the wire bus connection or to the edge where conductive ink has been applied. Connect to the (-) or black jack on the Power Supply with a Black Plating Cable.
3. Connect a Red Plating Probe (Marked for Electroclean) to the Power Supply (+) or red jack using the Red Plating Cable.
4. Set the voltage on the Power Supply to setting recommended in Table 1.
5. Dip the Plating Probe into the Electroclean Plating Solution. Wait a few seconds for the solution to saturate the Anode wrapping.
6. Swab the entire surface to be plated by brushing the surface with the saturated Plating Probe. The Plating Probe should be moved back and forth briskly to prevent burning and to provide even coverage. (See Figure 7) Swab the area for the time recommended in Table 1.
7. Thoroughly rinse the entire area with water. Any burning or darkening of the contacts may be removed with an Abrasive Pad. Saturate the Abrasive Pad and the circuit board surface with water and lightly buff the contacts until all evidence of the burning or discoloring is removed. Rinse the entire area with water.

Caution

Do not allow the rework area to dry out between steps. The water coating prevents oxidation.

8. Connect a Red Plating Probe (Marked for Nickel) to the Power Supply (+) or red jack using the Red Plating Cable.
9. Set the voltage on the Power Supply to setting recommended in Table 1.
10. Dip the Plating Probe into the Nickel Plating Solution. Wait a few seconds for the solution to saturate the Anode wrapping.
11. Swab the entire surface to be plated by brushing the surface with the saturated Plating Probe. The Plating Probe should be moved back and forth briskly to prevent burning and to provide even coverage. (See Figure 7) Swab the area for the time recommended in Table 1. Before rinsing, lightly buff the contacts with an abrasive pad.
12. Thoroughly rinse the entire area with water.
13. Connect a Red Plating Probe (Marked for Gold) to the Power Supply (+) or red jack using the Red Plating Cable.
14. Set the voltage on the Power Supply to setting recommended in Table 1.
15. Dip the Plating Probe into the Gold Plating Solution. Wait a few seconds for the solution to saturate the Anode wrapping.
16. Swab the entire surface to be plated by brushing the surface with the saturated Plating Probe. The Plating Probe should be moved back and forth briskly to prevent burning and to provide even coverage. Swab the area for the time recommended in Table 1.
17. Swab the entire surface to be plated by brushing the surface with the saturated plating probe. The plating probe should be moved back and forth briskly to prevent burning and to provide even coverage. Swab the area for the time recommended by the equipment manufacturer. Refer to Table 1 for general voltage/time settings.
18. Thoroughly rinse the entire area with water.
19. Remove and discard all Plating Tape and thoroughly rinse the area with water. Dry the area using wipes.

20. If a wire was used to buss the contacts remove it using a Soldering Iron. Apply Kapton Tape to protect the contacts from further contamination while removing the bus connection.
21. If conductive ink was used to buss the contacts remove it using a the Conformal Coating Remover Pen.
22. Thoroughly rinse the entire area with water or rinse the circuit board in an aqueous water cleaning system.

Table 1
Typical Voltage/Time Settings

Surface Area	Electroclean		Nickel		Gold	
	Volts	Time	Volts	Time	Volts	Time
<.01 in ²	9.0 VDC	5 sec.	4.5 VDC	10 sec.	3.0 VDC	10 sec.
.01 - .05 in ²	9.0 VDC	5 sec.	4.5 VDC	30 sec.	3.0 VDC	20 sec.
.05 - .10 in ²	9.0 VDC	5 sec.	4.5 VDC	1.0 min.	4.5 VDC	30 sec.
.10 - .20 in ²	9.0 VDC	10 sec.	4.5 VDC	2.0 min.	4.5 VDC	1.0 min.
.20 - .30 in ²	9.0 VDC	10 sec.	4.5 VDC	2.5 min.	4.5 VDC	1.5 min.
.30 - .40 in ²	9.0 VDC	10 sec.	4.5 VDC	3.0 min.	4.5 VDC	2.0 min.
.40 - .50 in ²	9.0 VDC	20 sec.	4.5 VDC	4.0 min.	4.5 VDC	2.5 min.
.50 - .60 in ²	9.0 VDC	20 sec.	4.5 VDC	5.0 min.	4.5 VDC	3.0 min.
.60 - .70 in ²	9.0 VDC	20 sec.	6.0 VDC	6.0 min.	4.5 VDC	3.5 min.
.70 - .80 in ²	9.0 VDC	30 sec.	6.0 VDC	7.0 min.	4.5 VDC	4.0 min.
.80 - .90 in ²	9.0 VDC	30 sec.	6.0 VDC	7.5 min.	4.5 VDC	4.5 min.
.90 - 1.00 in ²	9.0 VDC	30 sec.	6.0 VDC	8.0 min.	4.5 VDC	5.0 min.

Notes:

1. Surface Area is the total area being plated during each swab plating operation.
2. Voltage and Time setting shown in Table 1 are for a minimum of .000100" Nickel and .000050" Gold.
3. Settings are a guide, for precise thickness requirements the final thickness should be verified with measuring equipment

Evaluation

1. Rework area should be checked by measuring the thickness to make sure they meet the minimum thickness requirement.
2. The plating bond may be checked by doing a peel test using Peel Testing Tape.
3. Visually examine the rework area for color and luster.

Surface Mount Pad Repair

Outline

This procedure is used to replace damaged and missing surface mount pads. The damaged surface mount pads are replaced with new dry film, adhesive backed surface mount pads. The new surface mount pads are bonded to the circuit board surface using a Bonding Iron or Circuit Bonding System.

Note

It is strongly recommended that a Circuit Bonding System be used when replacing very small circuits such as surface mount pads. (See page 11 for information on the Circuit Bonding System)

IPC Reference*

4.7.2 Surface Mount Pad Repair, Film Adhesive Method

Kits/Systems

Part No.	Description
201-1100	Micro Pad Repair Kit (See page 5)
201-2100	Professional Kit (See page 2)

Tools/Materials

Part No.	Description
115-3102	Bonding Iron, 120 VAC
-----	Bonding Tips, Various Sizes
-----	Circuit Frames, Various (See page 15)
115-3302	Epoxy (See page 26)
-----	Flux
355-2102	Knife
115-3314	Mixing Stick
115-3312	Plastic Cup
115-3360	Plastic Probe
-----	Solder
-----	Soldering Iron
950-4508	Tape, Kapton
335-5183	Tweezer
Optional Items	
115-3118	Circuit Bonding System
-----	Microscope
-----	Oven

Procedure

1. Remove the defective surface mount pad and a short length of the connecting circuit, if any. (See Figure 1)

Skill Level: Advanced
Conformance Level: High

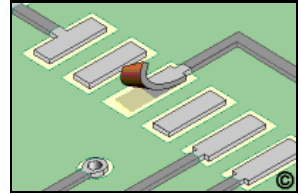

Damaged Surface Mount Pad

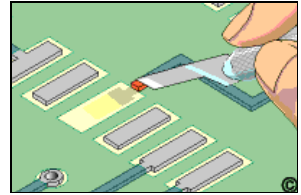

Figure 1: Remove the defective pad and soldermask from the connecting circuit.

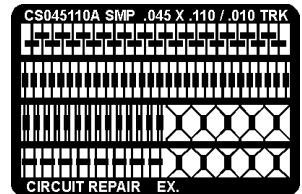

Figure 2: Select a replacement surface mount pad that matches the missing pad.

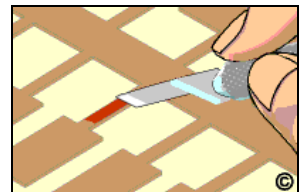

Figure 3: Scrape off the bonding film from solder joint area on the back side.

2. Scrape off any residue, contamination or burned material from the board surface.
3. Scrape off any solder mask or coating from the connecting circuit and clean the area. (See Figure 1).
4. Apply a small amount of liquid flux to the connection area on the circuit board surface and tin with solder. Clean the area. The length of the overlap solder connection should be a minimum of 2 times the circuit width.
5. The area for the new surface mount pad on the board surface must be smooth and flat. If internal fibers of the board are exposed or if there are deep scratches in the surface they should be repaired. (See Base Board Repair procedure on page 46)
6. Select a replacement surface mount pad that most closely matches the size and shape of the missing surface mount pad. (See Figure 2).
7. Before trimming out the new surface mount pad carefully scrape off the bonding film from the solder joint connection area on the back side. (See Figure 3).

Caution

Scrape off the bonding film only from the joint connection area. When handling the new surface mount pad avoid touching the bonding film to prevent contamination that may reduce the bond strength.

8. Cut out and trim the new surface mount pad. Cut out from the plated side. Cut the length to provide the maximum allowable circuit overlap for soldering. Minimum 2 times the circuit width. (See Figure 4).
9. Place a piece of Kapton Tape over the top surface of the new surface mount pad. Place the new surface mount pad in position on the circuit board surface using the Kapton Tape to aid in alignment.
10. Select a Bonding Tip to match the shape of the new surface mount pad and insert it into the Bonding Iron or Circuit Bonding System. Allow in the Bonding Iron or Circuit Bonding System 10 minutes to warm up.

Note

The Bonding Tip should be as small as possible but cover the entire surface of the new surface mount pad.

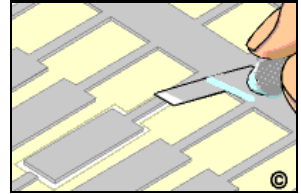

Figure 4: Cut out the new surface mount pad. Cut from the plated side.

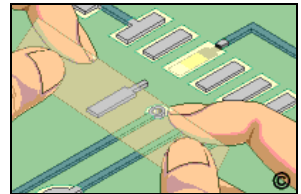

Figure 5: Place the new surface mount pad in position using Kapton Tape.



Figure 6: Bond the new pad with a Bonding Iron or Circuit Bonding System.

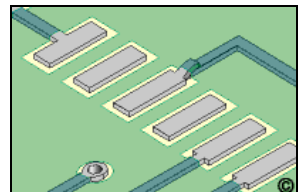

Figure 7: Completed surface mount pad repair.

11. Position the circuit board so that it is flat and stable. Gently place the hot Bonding Tip onto the tape covering the new surface mount pad. Apply light downward pressure for 5 seconds to tack the new surface mount pad in place. (See Figure 6).
12. Carefully peel off the Tape. Gently place the Bonding Tip directly onto the new surface mount pad. Apply light downward pressure for an additional 30 seconds to fully bond the new surface mount pad.
13. Inspect the new surface mount pad for proper alignment.
14. If the new surface mount pad has a connecting circuit apply a small amount of liquid flux to the lap solder joint connection area and solder the circuit from the new surface mount pad to the circuit on the circuit board surface.
15. Mix a package of Epoxy per the instructions on page 26.
Note
The circuit board may be preheated prior to applying Epoxy. A preheated circuit board will allow the Epoxy to easily flow and level out.
16. Coat the lap solder joint connection with Epoxy. A Wood Stick, Plastic Probe, or Syringe Assembly may be used to apply the Epoxy.
Note
Additional Epoxy can be applied around the perimeter of the new surface mount pad to provide additional bond strength.
17. Cure the Epoxy in an oven for 1 hour at 165° F (74° C) or at room temperature for 24 hours.

Evaluation

1. Visual examination of new surface mount pad width and spacing.
2. Electrical continuity measurement.

BGA Pad Repair

Outline

This procedure is used to replace damaged and missing Ball Grid Array (BGA) pads. The damaged BGA pads are replaced with new dry film, adhesive backed BGA pads. The new BGA pads are bonded to the circuit board surface using a Bonding Iron or Circuit Bonding System.

Note

It is strongly recommended that a Circuit Bonding System be used when replacing very small circuits such as BGA pads. (See page 11 for information on the Circuit Bonding System)

IPC Reference*

4.7.3 Surface Mount, BGA Pad Repair, Film Adhesive Method

Kits/Systems

Part No.	Description
201-1100	Micro Pad Repair Kit (See page 5)
201-2100	Professional Kit (See page 2)

Tools/Materials

Part No.	Description
115-3102	Bonding Iron, 120 VAC
-----	Bonding Tips, Various Sizes
-----	Circuit Frames, Various (See page 15)
115-3302	Epoxy (See page 26)
-----	Flux
355-2102	Knife
115-3314	Mixing Stick
115-3312	Plastic Cup
115-3360	Plastic Probe
-----	Solder
-----	Soldering Iron
950-4508	Tape, Kapton
335-5183	Tweezer
Optional Items	
115-3118	Circuit Bonding System
-----	Microscope
-----	Oven

Procedure

1. Remove the defective BGA pad and a short length of the connecting circuit, if any. (See Figure 1)

Skill Level: Advanced
Conformance Level: High

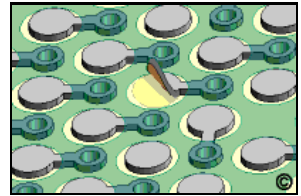

Damaged BGA Pad

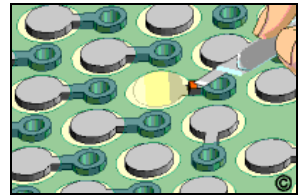

Figure 1: Remove the defective BGA pad and soldermask from the connecting circuit.



Figure 2: Select a replacement BGA pad that matches the missing pad.

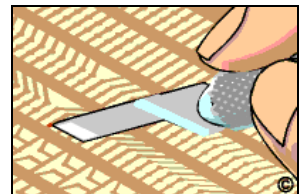

Figure 3: Scrape off the bonding film from solder joint area on the back side.

2. Scrape off any residue, contamination or burned material from the board surface.
3. Scrape off any solder mask or coating from the connecting circuit and clean the area. (See Figure 1).
4. Apply a small amount of liquid flux to the connection area on the circuit board surface and tin with solder. Clean the area. The length of the overlap solder connection should be a minimum of 2 times the circuit width.
5. The area for the new surface mount pad on the board surface must be smooth and flat. If internal fibers of the board are exposed or if there are deep scratches in the surface they should be repaired. (See Base Board Repair procedure on page 46)

Note

The height of the replaced BGA pad can be critical, especially for eutectic balled parts. Remove any solder mask between the BGA pad and the connecting circuit or via hole on the board surface to maintain a low profile. When necessary, mill slightly into the board surface to ensure that the connecting circuit height does not interfere with the replaced BGA component.

6. Select a replacement BGA pad that most closely matches the size and shape of the missing BGA pad. (See page 17 for selection of sizes and shapes)
7. Before trimming out the new BGA pad carefully scrape off the bonding film from the solder joint connection area on the back side. (See Figure 3).

Caution

Scrape off the bonding film only from the joint connection area. When handling the new BGA pad avoid touching the bonding film to prevent contamination that may reduce the bond strength.

8. Cut out and trim the new BGA pad. Cut out from the plated side. Cut the length to provide the maximum allowable circuit overlap for soldering. Minimum 2 times the circuit width.
9. Place a piece of Kapton Tape over the top surface of the new BGA pad. Place the new BGA pad in position on the circuit board surface using the Kapton Tape to aid in alignment.
10. Select a Bonding Tip to match the shape of the new BGA pad and insert it into the Bonding Iron or Circuit Bonding

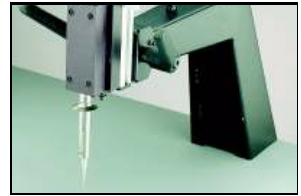

Figure 4: Bond the new BGA pad with a Bonding Iron or Circuit Bonding System.

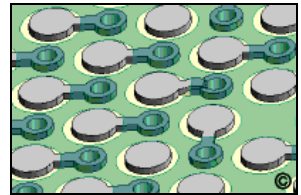

Figure 5: Completed BGA pad repair.

System. Allow in the Bonding Iron or Circuit Bonding System 10 minutes to warm up.

Note

The Bonding Tip should be as small as possible but cover the entire surface of the new BGA pad.

11. Position the circuit board so that it is flat and stable. Gently place the hot Bonding Tip onto the tape covering the new BGA pad. Apply light downward pressure for 5 seconds to tack the new BGA pad in place. (See Figure 4).
12. Carefully peel off the Tape. Gently place the Bonding Tip directly onto the new BGA pad. Apply light downward pressure for an additional 30 seconds to fully bond the new BGA pad.
13. Inspect the new BGA pad for proper alignment.
14. If the new BGA pad has a connecting circuit apply a small amount of liquid flux to the lap solder joint connection area and solder the circuit from the new BGA pad to the circuit on the circuit board surface.
15. Mix a package of Epoxy per the instructions on page 26.
Note
The circuit board may be preheated prior to applying Epoxy. A preheated circuit board will allow the Epoxy to easily flow and level out.
16. Coat the lap solder joint connection with Epoxy. A Wood Stick, Plastic Probe, or Syringe Assembly may be used to apply the Epoxy.
Note
Additional Epoxy can be applied around the perimeter of the new BGA pad to provide additional bond strength.
17. Cure the Epoxy in an oven for 1 hour at 165° F (74° C) or at room temperature for 24 hours.

Evaluation

1. Visual examination of new BGA pad width and spacing.
2. Electrical continuity measurement.

Plated Hole Repair

Outline

This procedure covers the repair of a damaged hole that has no inner layer connection. An eyelet is used to repair the damage to the hole and the eyelet flanges replace the lands on the circuit board surface.

Note

This procedure is used only to restore the integrity of a through connection in a double sided circuit board or a multilayer board where there is no inner layer connection. If there is an inner layer connection visit our web site at www.circuitmedic.com.

IPC Reference*

5.1 Plated Hole Repair, No Inner Layer Connection

Kits/Systems

<u>Part No.</u>	<u>Description</u>
201-3140	Plated Hole Repair Kit (See page 18)
110-5202	Eyelet Press (See page 20)

Tools/Materials

<u>Part No.</u>	<u>Description</u>
-----	Ball Mills, Various Sizes
-----	Cleaner
-----	Eyelet Press (See page 20)
-----	Eyelets, Various Sizes (See page 22)
-----	Flux
110-4102	Micro-Drill System (See page 31)
115-3138	Mill Handle
-----	Pin Gauges
115-3120	Setting Tool
-----	Solder
-----	Soldering Iron
115-3122	Tool Base
115-3134	Tool Handle
-----	Wipes
<u>Optional Items</u>	
-----	Microscope

Skill Level: Intermediate
Conformance Level: High

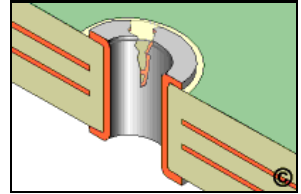

Damaged Plated Hole



Figure 1: Drill out the hole using a Micro-Drill System or Mill Handle and Ball Mill.

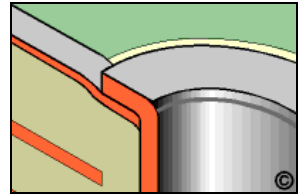

Figure 2: The eyelet flange can be used to secure a new circuit in place.



Figure 3: Eyelets can be set in place using an Eyelet Press.

Eyelet Selection Criteria

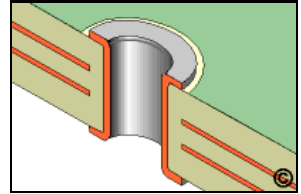
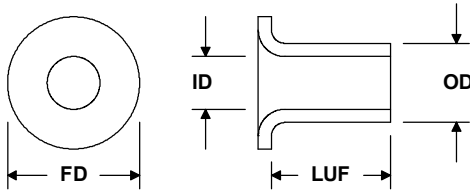

Figure 4: Completed repair.

ID - Inside Diameter

The eyelet inside diameter should be a .075 - .500 mm (.003"-.020") greater than the component lead diameter.

LUF - Length Under Flange

The length of the eyelet barrel under the flange should be .630 - .890 mm (.025" - .035") greater than the thickness of the circuit board. This added length allows for proper protrusion when setting the eyelet.

FD - Flange Diameter

The eyelet flange diameter should be small enough to prevent interference with adjacent lands or circuits.

OD - Outside Diameter

The clearance hole should allow the eyelet to be inserted without force but should not exceed .125 mm (.005") greater than the eyelet outside diameter.

Note

Be sure to select an eyelet meeting the proper criteria. An eyelet with an oversize flange may interfere with adjacent circuits. An eyelet that is too short will not protrude through the circuit board for proper setting.

Procedure

1. Select an Eyelet using the Eyelet Selection Criteria. Use a Pin Gauge to measure the existing plated hole size.
2. Insert the appropriate ball mill into the Mill handle or Micro-Drill System. Mill out the hole removing all the plating. The milled hole should be .025 - .125 mm (.001" - .005") larger than the eyelet O.D. (See Figure 1).

Caution

This procedure may isolate internal connections on multilayer circuit boards.

-
3. Clean the area.
 4. Apply a small amount of liquid flux to the land or circuit on the circuit board surface, if any, and tin with solder. Clean the area.
 5. Insert the Eyelet into the hole. If a new circuit is required, the new circuit may extend into the milled hole and the flange of the Eyelet will secure the new circuit in place. (See Figure 2).
 6. Prepare the Setting Tools or Eyelet Press system. (See Figure 3).
 7. Turn the circuit board over and rest the Eyelet flange on the lower setting tool.
 8. Apply firm even pressure to form the eyelet barrel.
Note
Inspect the eyelet flange for evidence of damage.
 9. Apply a small amount of liquid flux and solder the eyelet flanges to the lands on the circuit board surface if necessary. Clean the area. Inspect for good solder flow and wetting around the eyelet flanges and lands.

Evaluation

1. Visual examination, dimensional requirement of flange diameter and Eyelet inside diameter.
2. Electrical continuity measurement.

CircuitMedic
135 Ward Hill Avenue
Haverhill, MA 01835 USA
Phone: 978-373-1600
www.circuitmedic.com
info@circuitmedic.com

Manual No. 115-1803
Revision B

© Copyright 2006